

Top View

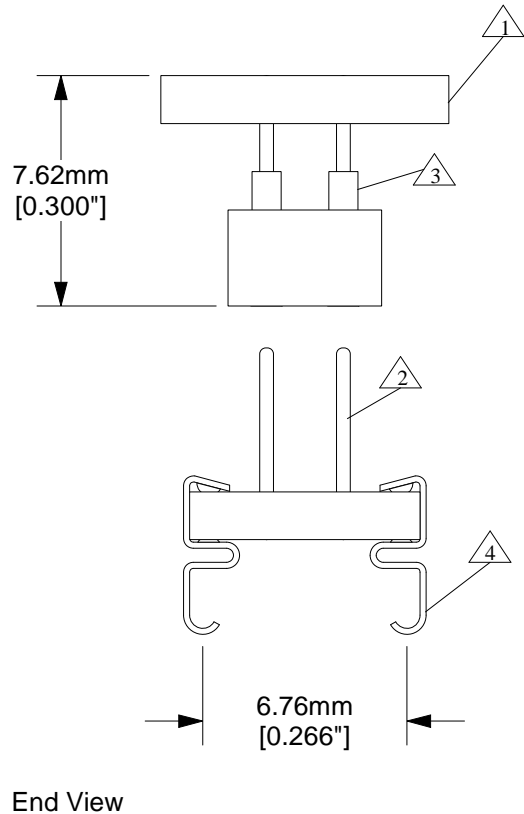
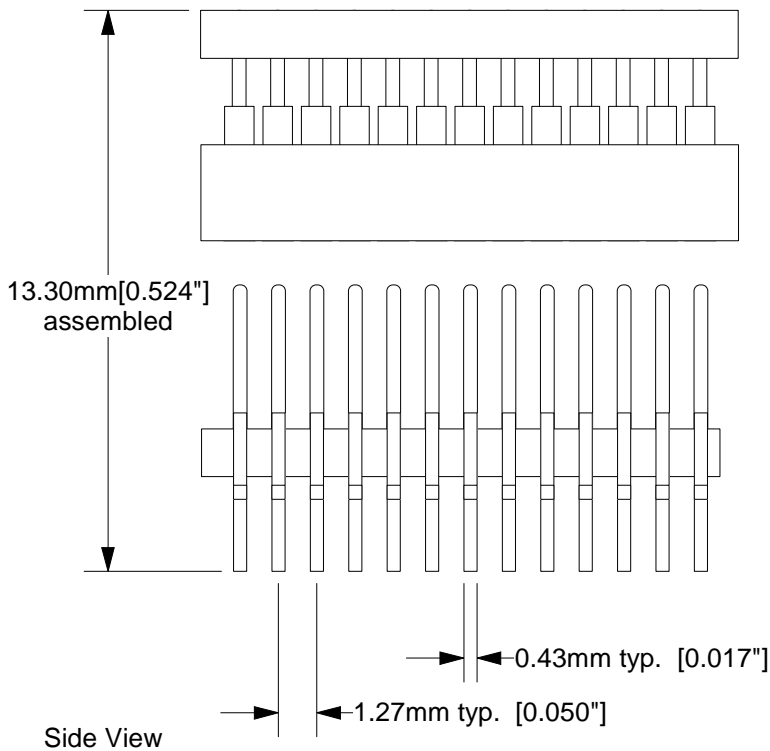

△1 Substrate: 1.59mm ±0.18mm [0.0625" ±0.007"]
FR4/G10 or equivalent high temp material. 17µm [1/2 oz.] Cu clad. SnPb plating.

△2 Pins: material- Brass Alloy 360 1/2 hard; finish- 0.25µm [10µ"] Au over 1.27µm [50µ"] Ni (min.).

△3 Pins: shell material- Brass Alloy 360 1/2 hard; finish- 0.25µm [10µ"] Au over 1.27µm [50µ"] Ni (min.). Contact material- BeCu; finish 0.25µm [10µ"] Au over 2.54µm [100µ"] Ni (min.).

△4 Leads: material- BeCu Alloy 194; plating- 60/40 SnPb 3.80-10.16µm [150-400µ"].

Description: CARRIER ADAPTOR:

A two piece surface mountable device converting from a 26 position land pattern to a 26 position surface mount foot. Corresponds to Ironwood SOJ26A Spec.

Tolerances: diameters ±0.03mm [±0.001"], PCB perimeters ±0.13mm [±0.005"], PCB thicknesses ±0.18mm [±0.007"], pitches (from true position) ±0.08mm [±0.003"], all other tolerances ±0.13mm [±0.005"] unless stated otherwise.

CA-SOJ26A-S-J-01 Drawing		Status: Released	Scale: 3:1	Rev C
 <p>© 1997 IRONWOOD ELECTRONICS, INC. PO BOX 21151 ST. PAUL, MN 55121 Tele: (651) 452-8100 www.ironwoodelectronics.com</p>	Drawing: P Jasmin		Date: 2/8/97	
	File: CA0SOJ26A-S-J-01 Dwg		Modified: 5/18/00	