

GHz BGA Socket - Direct mount, solderless

Features

- Directly mounts to target PCB (needs tooling holes) with hardware.
- High speed, reliable Elastomer connection
- Minimum real estate required
- Compression plate distributes forces evenly
- Ball guide prevents over compression of elastomer
- Easily removable swivel socket lid

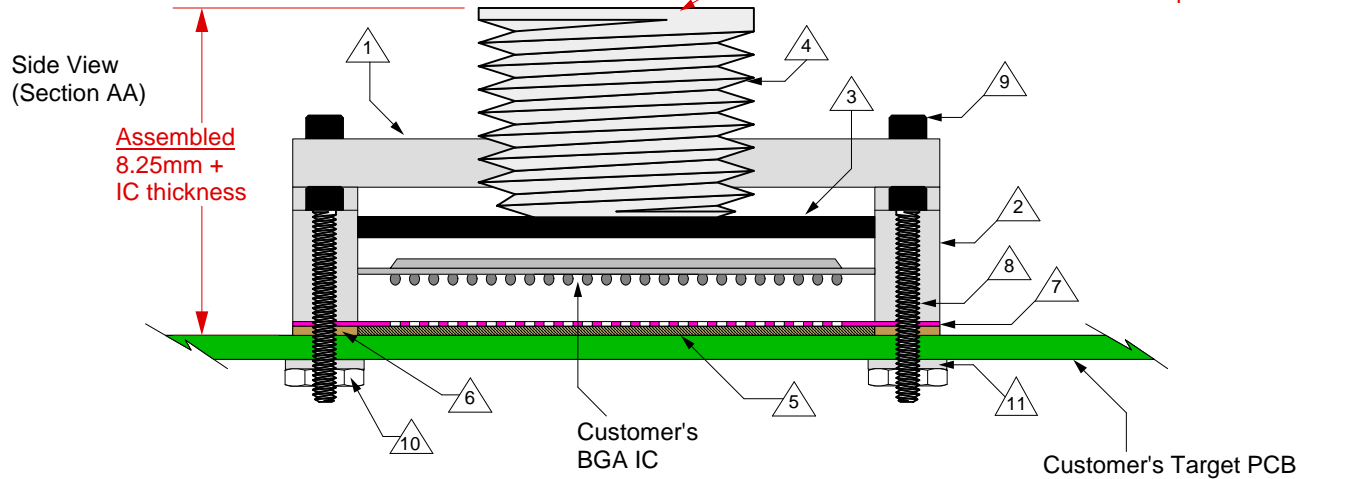
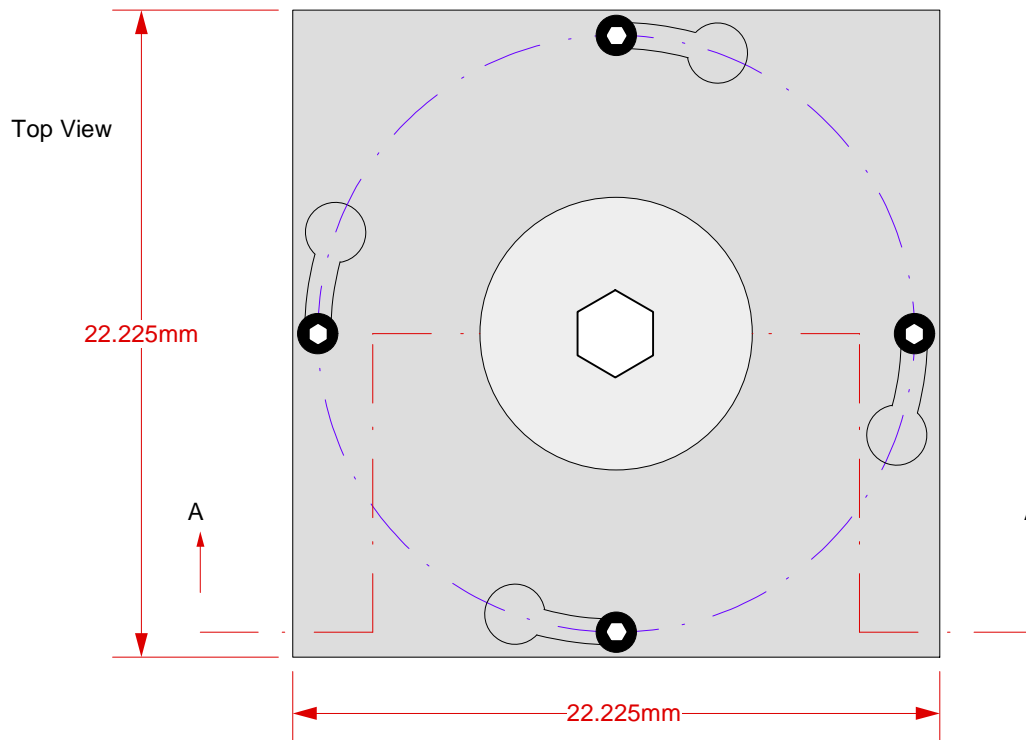

- △ 1 Socket Lid: Black anodized Aluminum. Thickness = 2.5mm.
- △ 2 Socket base: Black anodized Aluminum. Thickness = 5mm.
- △ 3 Compression Plate: Black anodized Aluminum. Thickness = 2.5mm.
- △ 4 Compression screw: Black anodized Aluminum. Thickness = 5mm, Hex socket = 5mm.
- △ 5 Elastomer: 40 micron dia gold plated brass filaments arranged symmetrically in a silicone rubber (63.5 degree angle). Thickness = 0.75mm.
- △ 6 Elastomer Guide: Non-clad FR4. Thickness = 0.725mm.
- △ 7 Ball Guide: Kapton polyimide.
- △ 8 Socket base screw: Socket head cap, Alloy steel with black oxide finish, 0-80 fine thread, 9.525mm long.
- △ 9 Socket lid screw: Shoulder screw, 18-8 SS, 0-80 fine thread.
- △ 10 Socket base nut: 18-8 Stainless steel, 0-80 fine thread.
- △ 11 Nylon washer: 1.73mm ID; 4.78mm OD 0.64mm thickness.

SG-BGA-6017 Drawing

Status: Released

Scale: -

Rev: E

© 2009 IRONWOOD ELECTRONICS, INC.
Tele: (952) 229-8200
www.ironwoodelectronics.com

Drawing: E Smolentseva

Date: 8/30/01

File: SG-BGA-6017 Dwg.mcd

Modified: 7/6/09, AE

All tolerances: $\pm 0.125\text{mm}$ (unless stated otherwise). Materials and specifications are subject to change without notice.

***Note: BGA pattern is not symmetrical with respect to the mounting holes.**

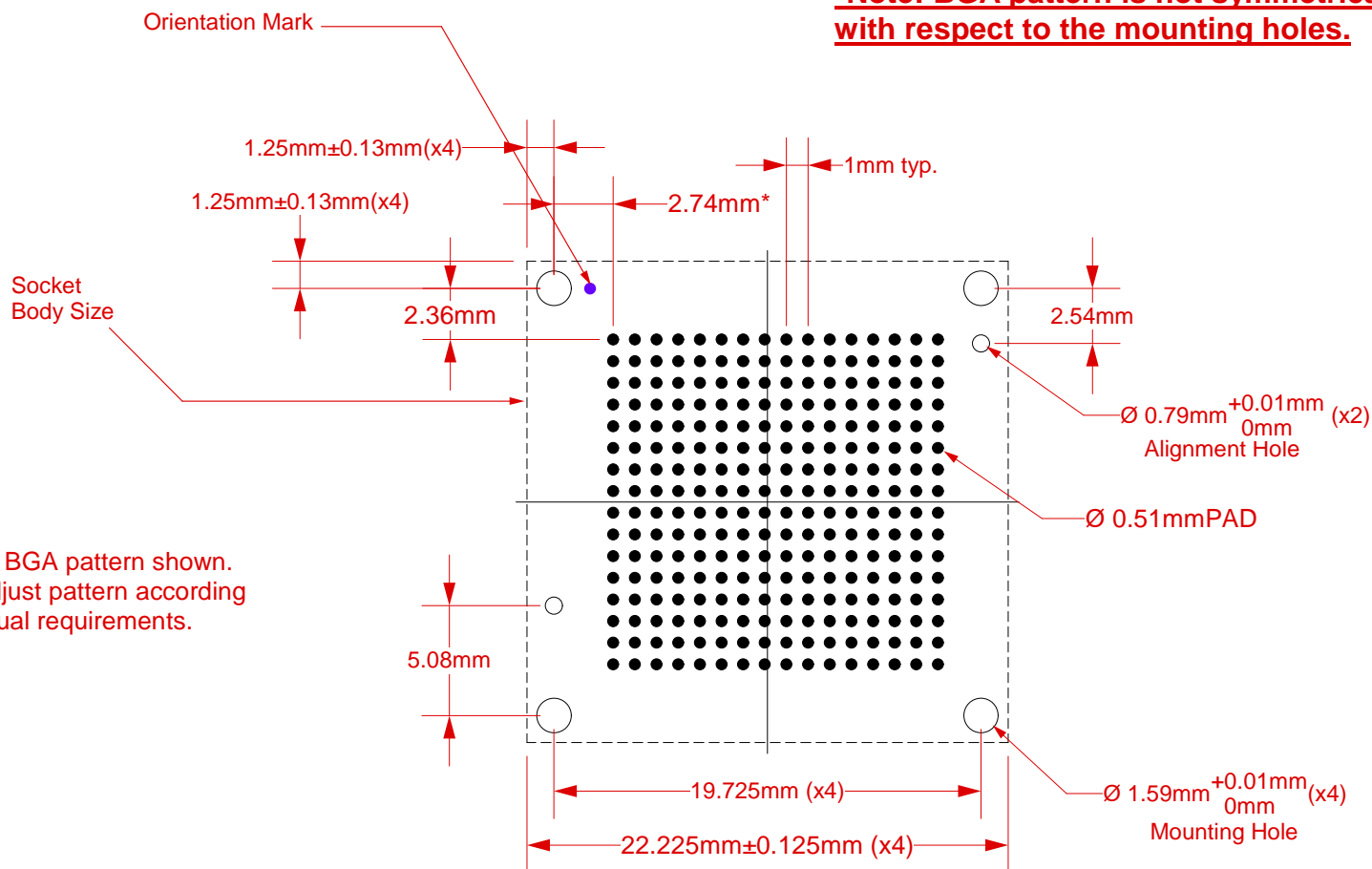

Note: Full BGA pattern shown. Please adjust pattern according to individual requirements.

Target PCB Recommendations

Total thickness: 1.6mm min.
Plating: Gold or Solder finish
PCB Pad height: Same or higher than solder mask

NOTE: Steel backing plate may be required based on end user's application

Recommended PCB Layout Tolerances: $\pm 0.025\text{mm} [\pm 0.001"]$ unless stated otherwise.

SG-BGA-6017 Drawing		Status: Released	Scale: 3:1	Rev: E
 <p>© 2009 IRONWOOD ELECTRONICS, INC. Tele: (952) 229-8200 www.ironwoodelectronics.com</p>	Drawing: E Smolentseva		Date: 8/30/01	
	File: SG-BGA-6017 Dwg.mcd		Modified: 7/6/09, AE	

TOP VIEW

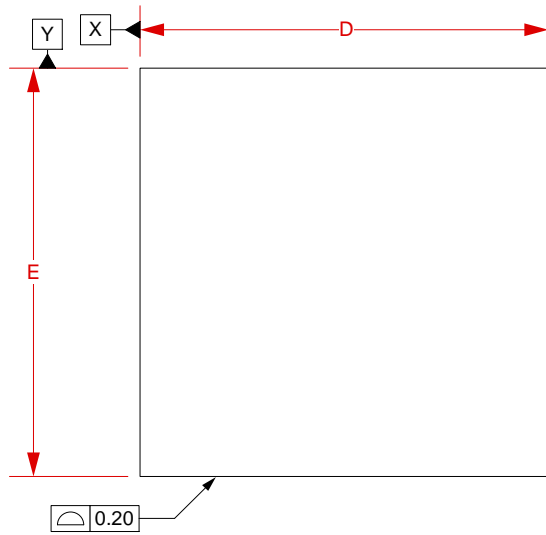

SIDE VIEW

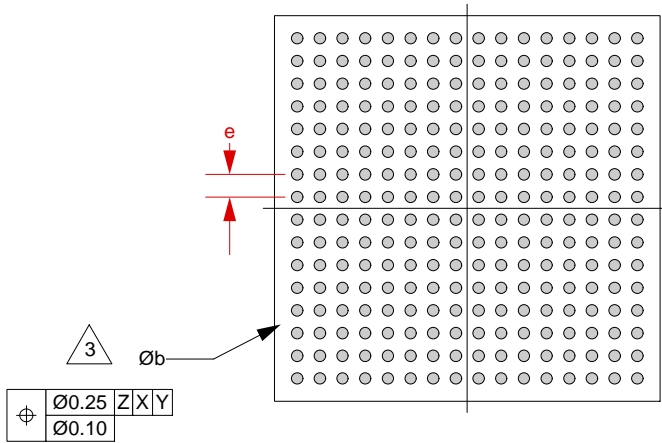
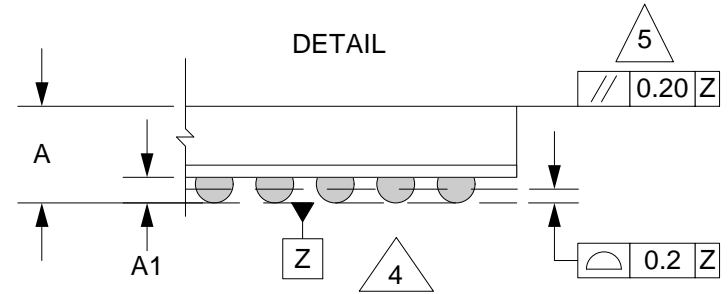
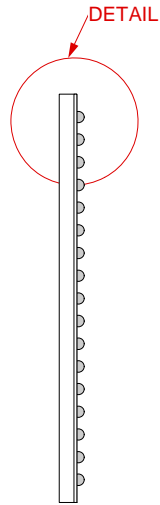

BOTTOM VIEW

- 1 Dimensions are in millimeters.
- 2 Interpret dimensions and tolerances per ASME Y14.5M-1994.
- 3 Dimension b is measured at the maximum solder ball diameter, parallel to datum plane Z.
- 4 Datum Z (seating plane) is defined by the spherical crowns of the solder balls.
- 5 Parallelism measurement shall exclude any effect of mark on top surface of package.

DIM	MIN	MAX
A		2.5
A1	0.4	0.6
b		0.70
D	17.00 BSC	
E	17.00 BSC	
e	1.0 BSC	

Array 16x16

	SG-BGA-6017 Drawing	Status: Released	Scale: -	Rev: E
	© 2009 IRONWOOD ELECTRONICS, INC. Tele: (952) 229-8200 www.ironwoodelectronics.com	Drawing: E Smolentseva		Date: 8/30/01
		File: SG-BGA-6017 Dwg.mcd		Modified: 7/6/09, AE