

# GHz BGA Socket - Direct mount, solderless

## Features

- Directly mounts to target PCB (needs tooling holes) with hardware.
- High speed, reliable Elastomer connection
- Minimum real estate required
- Compression plate distributes forces evenly
- Ball guide prevents over compression of elastomer
- Easily removable swivel socket lid

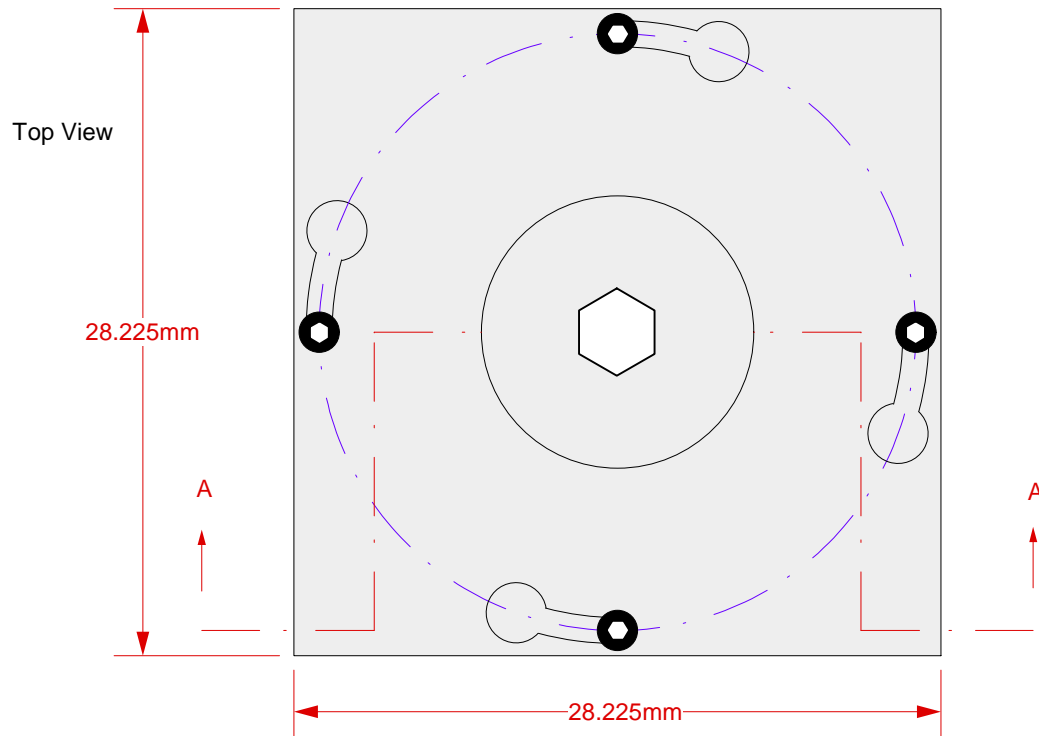

Side View  
(Section AA)

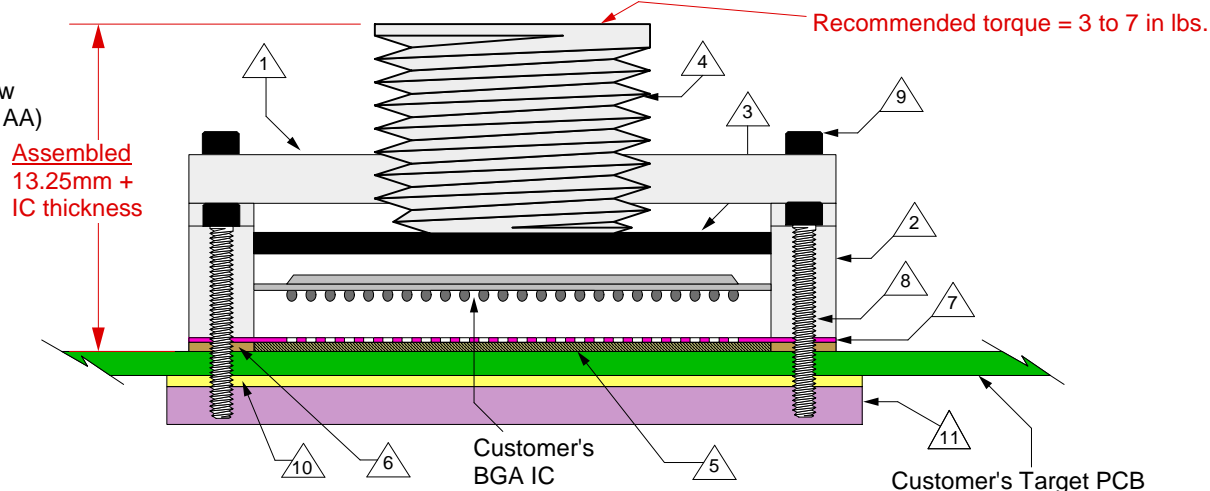

- |    |  |
|----|--|
| 1  | Socket Lid: Black anodized Aluminum.<br>Thickness = 2.5mm.   |
| 2  | Socket base: Black anodized Aluminum.<br>Thickness = 5mm.  |
| 3  | Compression Plate: Black anodized Aluminum.<br>Thickness = 2.5mm.  |
| 4  | Compression screw: Black anodized Aluminum.<br>Thickness = 5mm, Hex socket = 5mm.  |
| 5  | Elastomer: 40 micron dia gold plated brass filaments arranged symmetrically in a silicone rubber (63.5 degree angle).<br>Thickness = 0.75mm. |
| 6  | Elastomer Guide: Non-clad FR4.<br>Thickness = 0.725mm.   |
| 7  | Ball Guide: Kapton polyimide.  |
| 8  | Socket base screw: Socket head cap, alloy steel with black oxide finish, 0-80 fine thread, 12.7mm long.                                      |
| 9  | Socket lid screw: Shoulder screw, 18-8 SS, 0-80 fine thread.   |
| 10 | Insulation Plate: FR4/G10, Thickness = 1.59mm.   |
| 11 | Backing Plate: Black anodized Aluminum.<br>Thickness = 6.35mm.   |

## SG-BGA-6024 Drawing

Status: Released

Scale: NA

Rev: F

© 2009 IRONWOOD ELECTRONICS, INC.  
11351 Rupp Drive, Suite 400, Burnsville, MN 55337  
Tele: (952) 229-8200  
www.ironwoodelectronics.com

Drawing: H. Hansen

Date: 11/27/01

File: SG-BGA-6024 Dwg.mcd

Modified: 7/6/09, AE

All tolerances:  $\pm 0.125\text{mm}$  (unless stated otherwise). Materials and specifications are subject to change without notice.

Recommended PCB Layout  
Top View

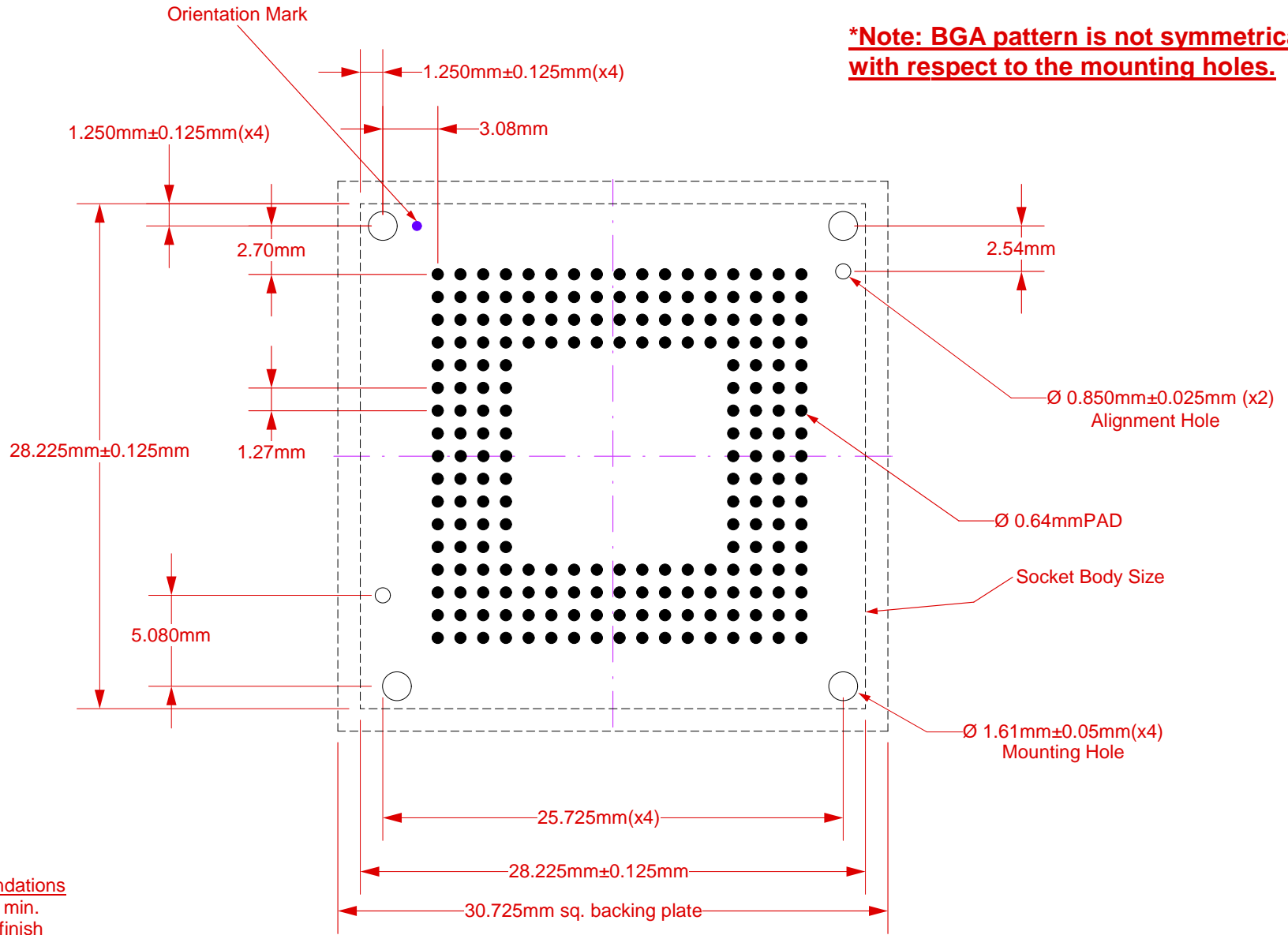

**\*Note: BGA pattern is not symmetrical with respect to the mounting holes.**

Target PCB Recommendations

Total thickness: 1.6mm min.  
Plating: Gold or Solder finish  
PCB Pad height: Same or higher than solder mask

NOTE: Steel backing plate may be required based on end user's application

Recommended PCB Layout Tolerances:  $\pm 0.025\text{mm}$  [ $\pm 0.001''$ ] unless stated otherwise.

	<b>SG-BGA-6024 Drawing</b>		Status: Released	Scale: 3:1	Rev: F	
	© 2009 IRONWOOD ELECTRONICS, INC. 11351 Rupp Drive, Suite 400, Burnsville, MN 55337 Tele: (952) 229-8200 www.ironwoodelectronics.com			Drawing: H. Hansen		Date: 11/27/01
				File: SG-BGA-6024 Dwg.mcd		Modified: 7/6/09, AE

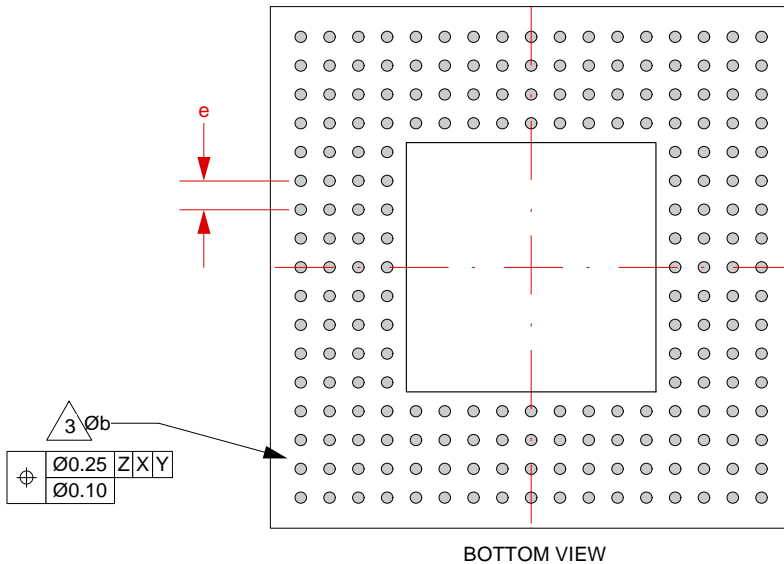
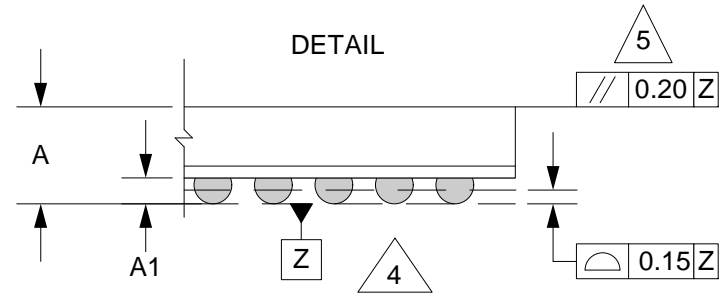
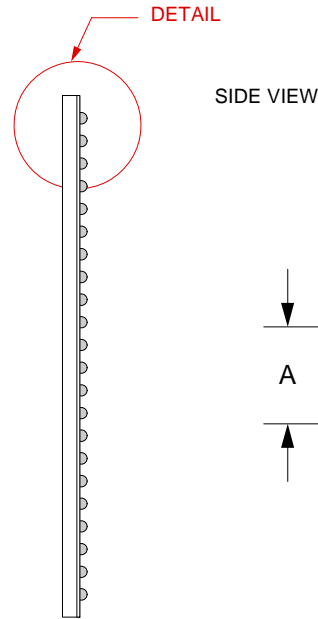
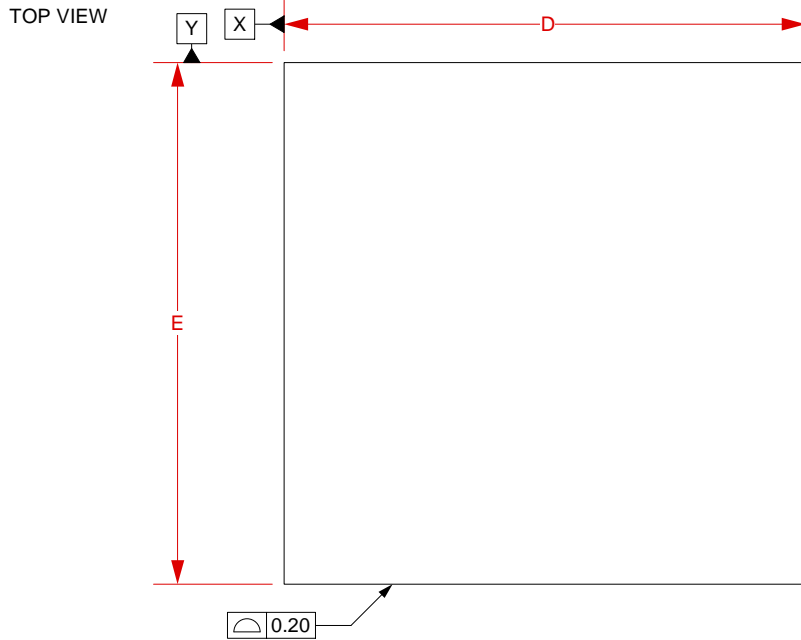

1. Dimensions are in millimeters.
  2. Interpret dimensions and tolerances per ASME Y14.5M-1994.
- 3 Dimension b is measured at the maximum solder ball diameter, parallel to datum plane Z.
- 4 Datum Z (seating plane) is defined by the spherical crowns of the solder balls.
- 5 Parallelism measurement shall exclude any effect of mark on top surface of package.

DIM	MIN	MAX
A		2.5
A1	0.6	0.7
b		0.85
D	23.00 BSC	
E	23.00 BSC	
e	1.27 BSC	

Array 17x17

 <p>© 2009 IRONWOOD ELECTRONICS, INC. 11351 Rupp Drive, Suite 400, Burnsville, MN 55337 Tele: (952) 229-8200 www.ironwoodelectronics.com</p>	<p><b>SG-BGA-6024 Drawing</b></p>	<p>Status: Released</p>	<p>Scale: -</p>	<p>Rev: F</p>
	<p>Drawing: H. Hansen</p>	<p>Date: 11/27/01</p>		
	<p>File: SG-BGA-6024 Dwg.mcd</p>	<p>Modified: 7/6/09, AE</p>		

Top View

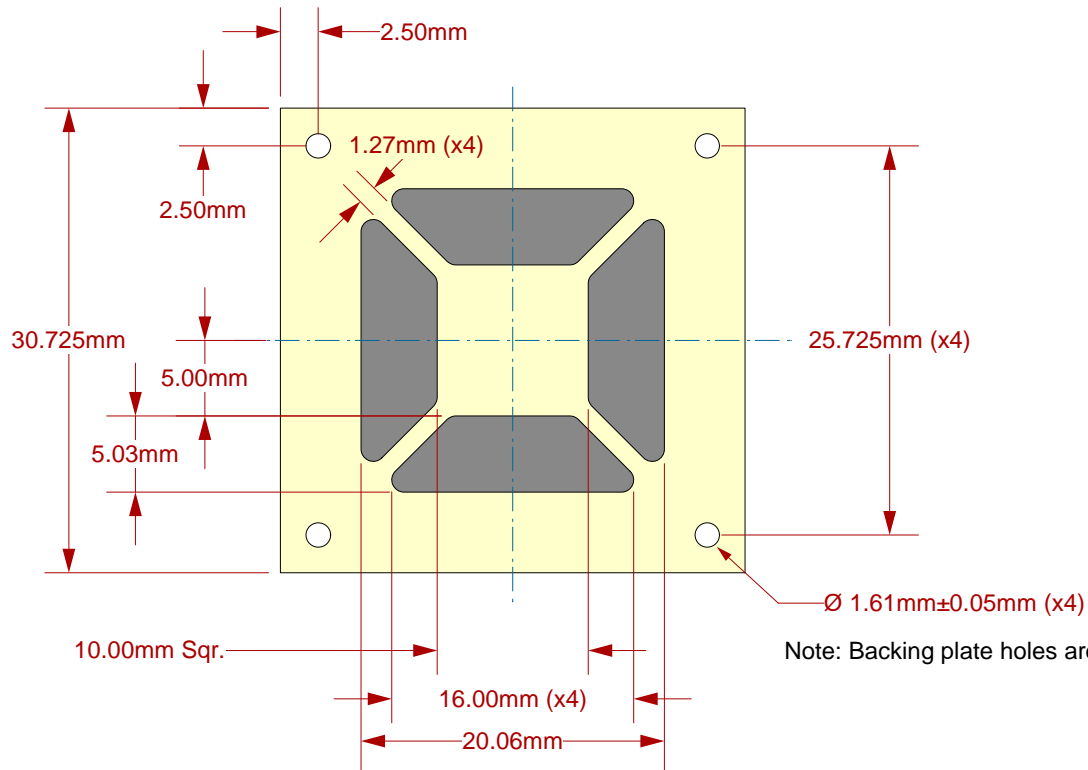

Side View



Description: Backing Plate with Insulation Plate

 <p>© 2009 IRONWOOD ELECTRONICS, INC. 11351 Rupp Drive, Suite 400, Burnsville, MN 55337 Tele: (952) 229-8200 www.ironwoodelectronics.com</p>	<p>Status: Released</p>	<p>Scale: -</p>	<p>Rev: F</p>
	<p>Drawing: H. Hansen</p>	<p>Date: 11/27/01</p>	
	<p>File: SG-BGA-6024 Dwg.mcd</p>	<p>Modified: 7/6/09, AE</p>	

All tolerances:  $\pm 0.125\text{mm}$  (unless stated otherwise). Materials and specifications are subject to change without notice.