

# GHz BGA Socket - Direct mount, solderless

## Features

- Directly mounts to target PCB (needs tooling holes) with hardware.
- High speed, reliable Elastomer connection
- Minimum real estate required
- Compression plate distributes forces evenly
- Ball guide prevents over compression of elastomer
- Easily removable swivel socket lid

Top View

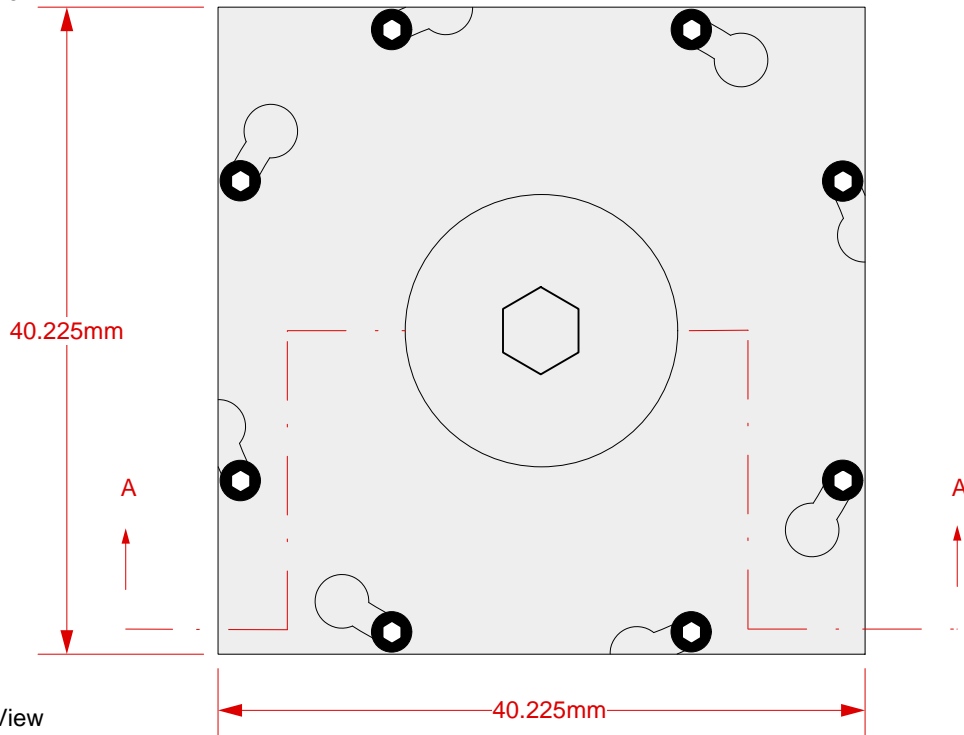

Side View  
(Section AA)

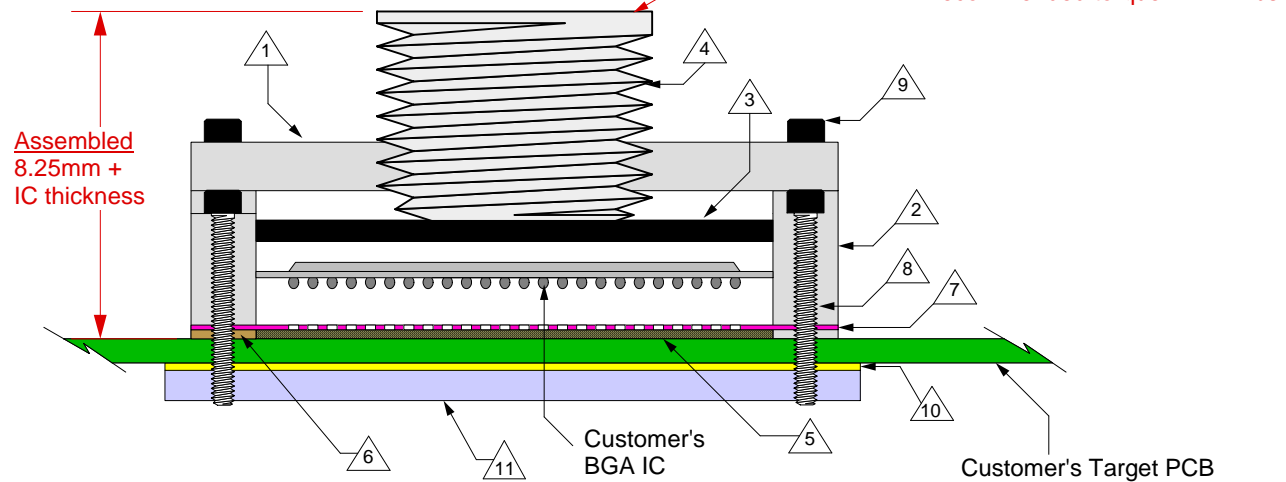

- 1 Socket Lid: Black anodized Aluminum. Thickness = 2.5mm.
- 2 Socket base: Black anodized Aluminum. Thickness = 6.5mm.
- 3 Compression Plate: Black anodized Aluminum. Thickness = 2.5mm.
- 4 Compression screw: Clear anodized Aluminum. Thickness = 5mm, Hex socket = 5mm.
- 5 Elastomer: 40 micron dia gold plated brass filaments arranged symmetrically in a silicone rubber (63.5 degree angle). Thickness = 0.75mm.
- 6 Elastomer Guide: Cirlex or equivalent. Thickness = 0.75mm.
- 7 Ball Guide: Kapton polyimide.
- 8 Socket base screw: Socket head cap, alloy steel with black oxide finish, 0-80 fine thread , 9.525mm long.
- 9 Socket lid screw: Shoulder screw, 18-8 SS, 0-80 fine thread.
- 10 Insulation Plate: FR4/G10, 1.59mm thick.
- 11 Backing Plate: Black anodized Aluminum. Thickness = 6.35mm.

## SG-BGA-6046 Drawing

© 2002 IRONWOOD ELECTRONICS, INC.  
PO BOX 21151 ST. PAUL, MN 55121  
Tele: (651) 452-8100  
www.ironwoodelectronics.com

Status: Released

Scale: -

Rev: F

Drawing: H. Hansen

Date: 4/17/02

File: SG-BGA-6046 Dwg.mcd

Modified: 5/19/09

All tolerances:  $\pm 0.125$ mm (unless stated otherwise). Materials and specifications are subject to change without notice.

PAGE 1 of 4

**Note: BGA pattern is not symmetrical with respect to the mounting holes.**

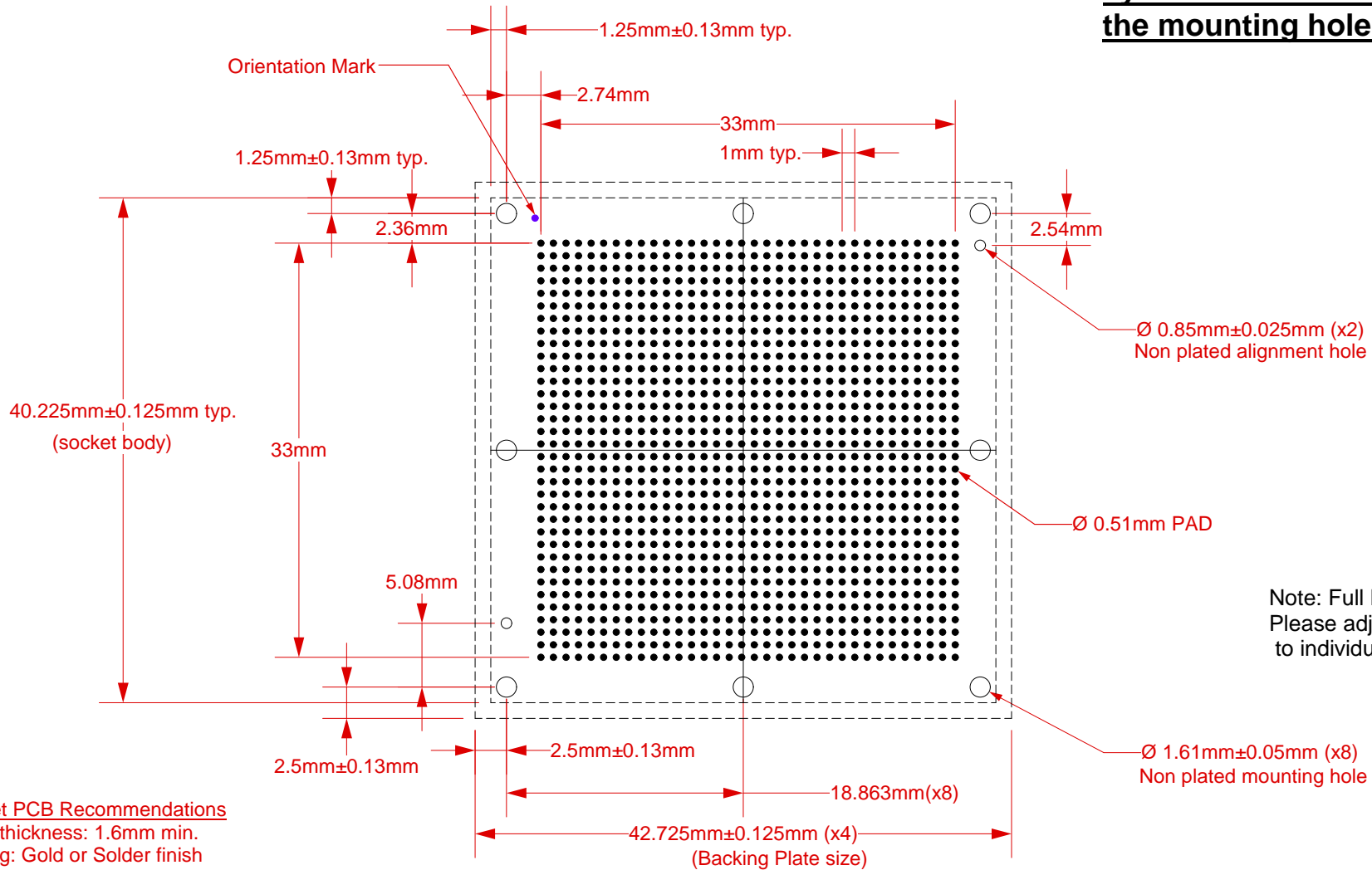

Note: Full BGA pattern shown. Please adjust pattern according to individual requirements.

**Target PCB Recommendations**

Total thickness: 1.6mm min.  
Plating: Gold or Solder finish  
PCB Pad height: Same or higher than solder mask

NOTE: Steel backing plate may be required based on end user's application

Recommended PCB Layout Tolerances:  $\pm 0.025\text{mm}$  [ $\pm 0.001''$ ] unless stated otherwise.

	<b>SG-BGA-6046 Drawing</b>	Status: Released	Scale: -	Rev: F
	© 2002 IRONWOOD ELECTRONICS, INC. PO BOX 21151 ST. PAUL, MN 55121 Tele: (651) 452-8100 www.ironwoodelectronics.com	Drawing: H. Hansen		Date: 4/17/02
		File: SG-BGA-6046 Dwg.mcd	Modified: 5/19/09	

Compatible BGA Spec

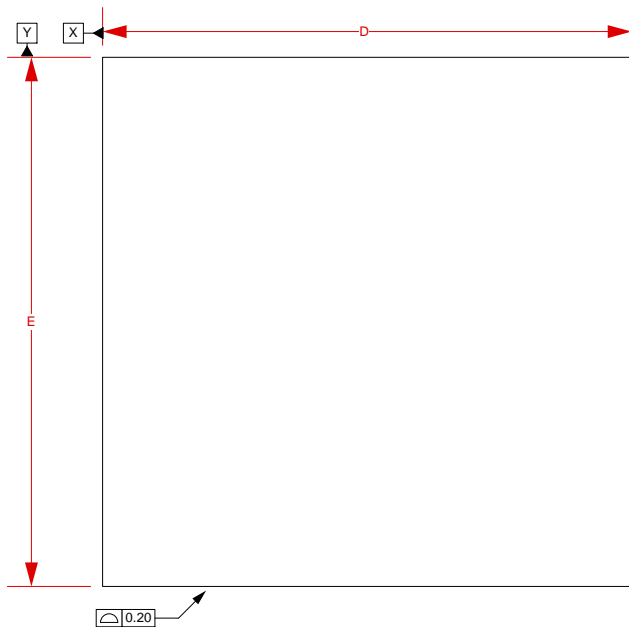

TOP VIEW

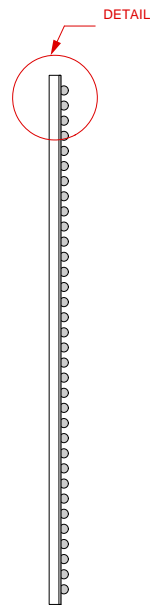

SIDE VIEW

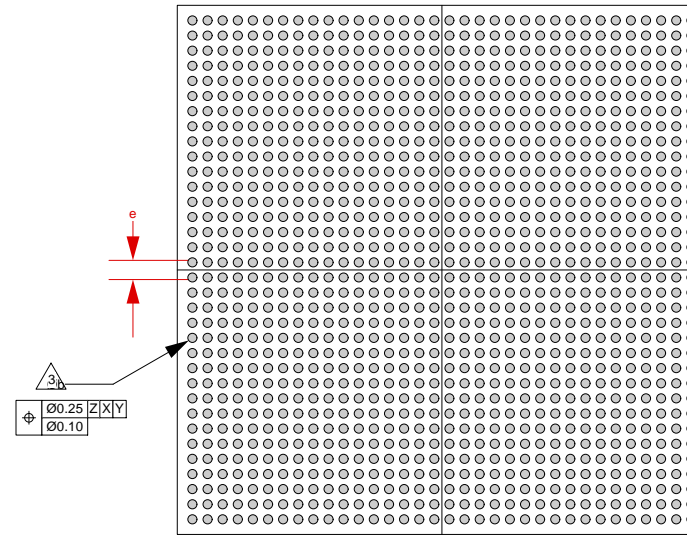

BOTTOM VIEW

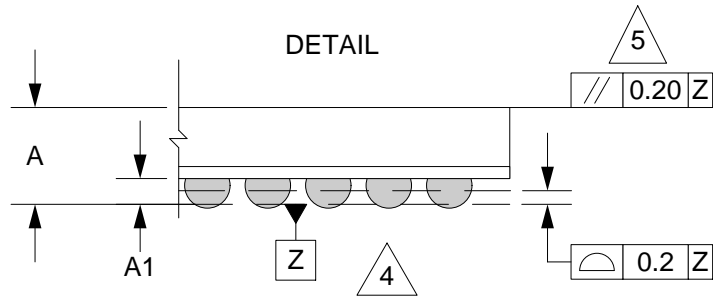

1. Dimensions are in millimeters.
  2. Interpret dimensions and tolerances per ASME Y14.5M-1994.
- 3. Dimension b is measured at the maximum solder ball diameter, parallel to datum plane Z.
  - 4. Datum Z (seating plane) is defined by the spherical crowns of the solder balls.
  - 5. Parallelism measurement shall exclude any effect of mark on top surface of package.

DIM	MIN	MAX
A		3.4
A1	0.4	0.6
b	0.5	0.7
D	35.0 BSC	
E	35.0 BSC	
e	1.00 BSC	

Array 34x34

	<b>SG-BGA-6046 Drawing</b>	Status: Released	Scale: -	Rev: F
	© 2002 IRONWOOD ELECTRONICS, INC. PO BOX 21151 ST. PAUL, MN 55121 Tele: (651) 452-8100 www.ironwoodelectronics.com	Drawing: H. Hansen		Date: 4/17/02
		File: SG-BGA-6046 Dwg.mcd	Modified: 5/19/09	

Top View

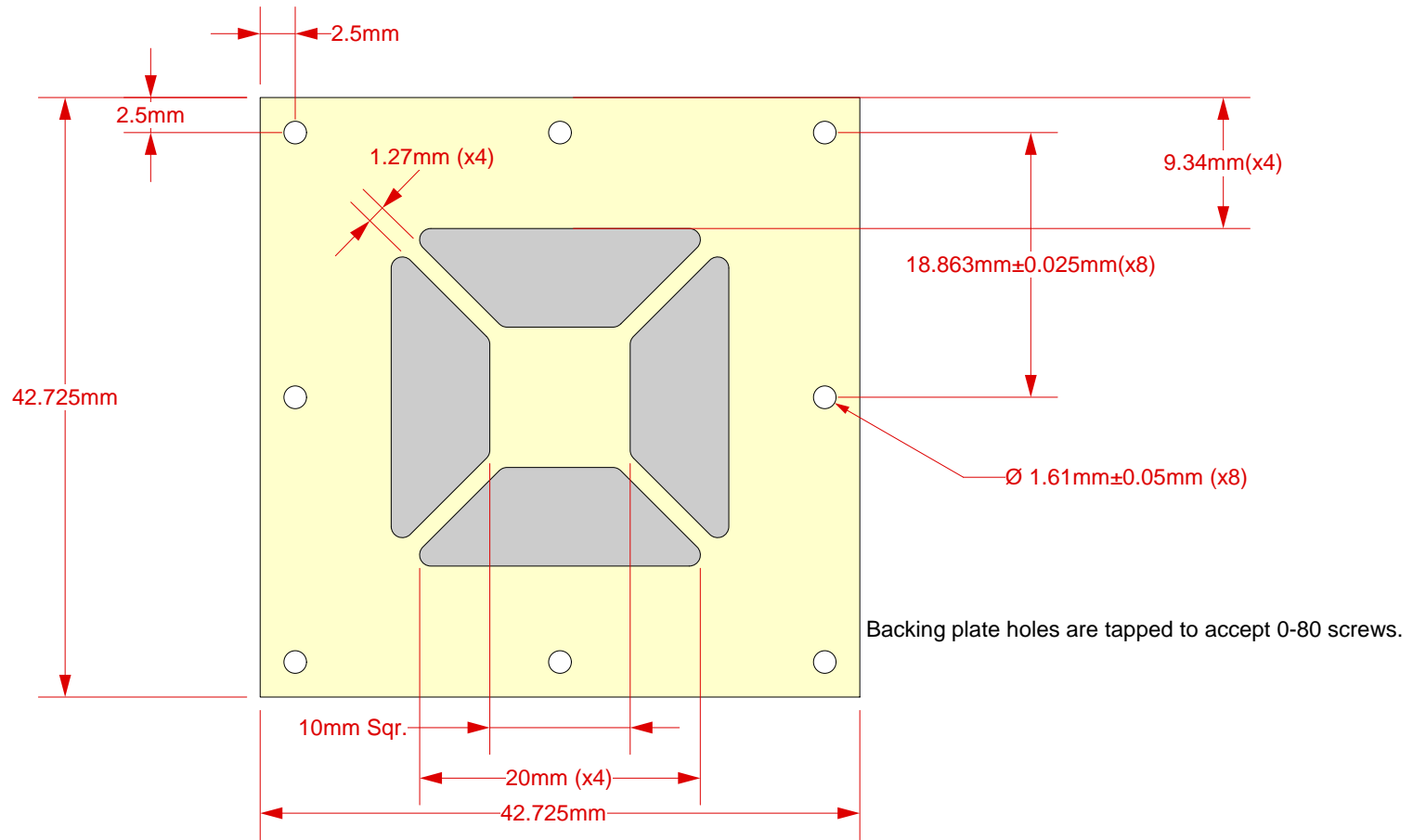

Side View

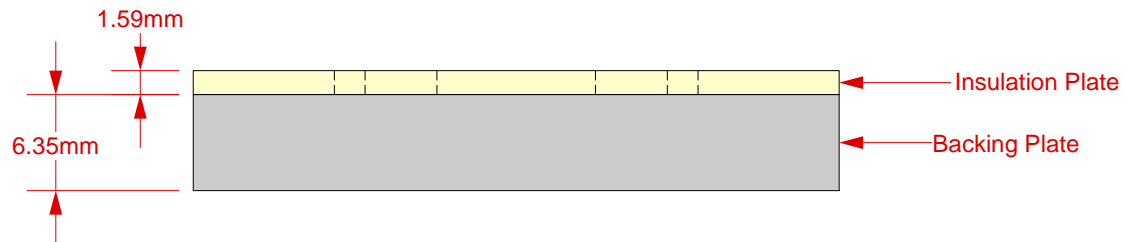

Description: Insulation Plate and Backing Plate

### SG-BGA-6046 Drawing

© 2002 IRONWOOD ELECTRONICS, INC.  
 PO BOX 21151 ST. PAUL, MN 55121  
 Tele: (651) 452-8100  
 www.ironwoodelectronics.com

Status: Released

Scale: -

Rev: F

Drawing: H. Hansen

Date: 4/17/02

File: SG-BGA-6046 Dwg.mcd

Modified: 5/19/09