

GHz BGA Socket - Direct mount, solderless

Features

- Directly mounts to target PCB (needs tooling holes) with hardware.
- High speed, reliable Elastomer connection
- Minimum real estate required
- Compression plate distributes forces evenly
- Ball guide prevents over compression of elastomer
- Easily removable swivel socket lid

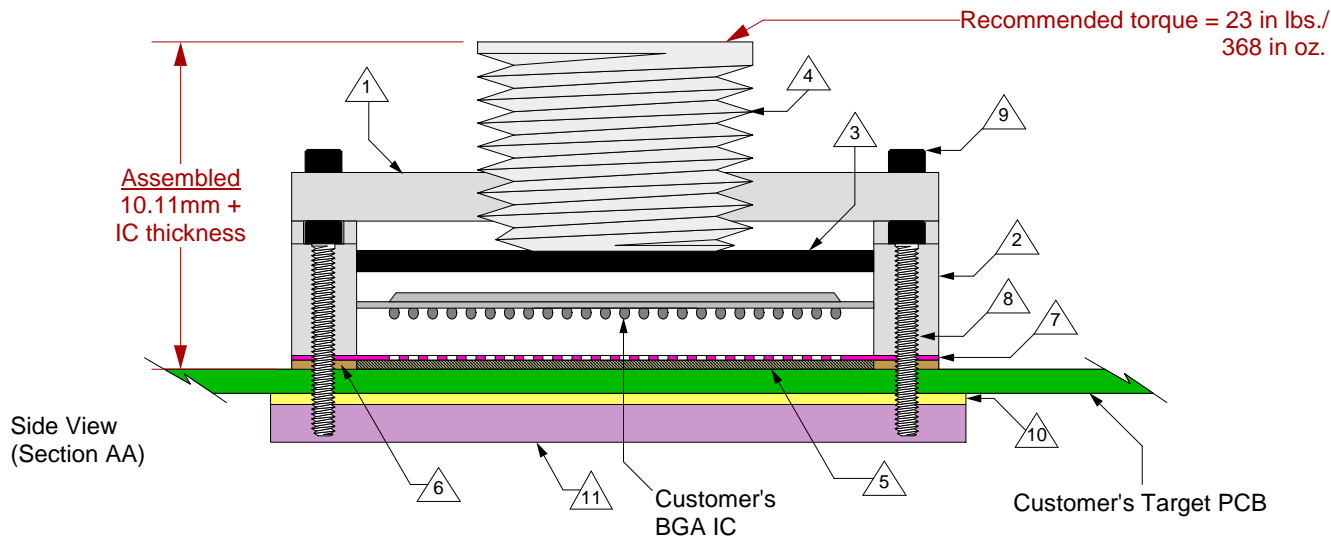
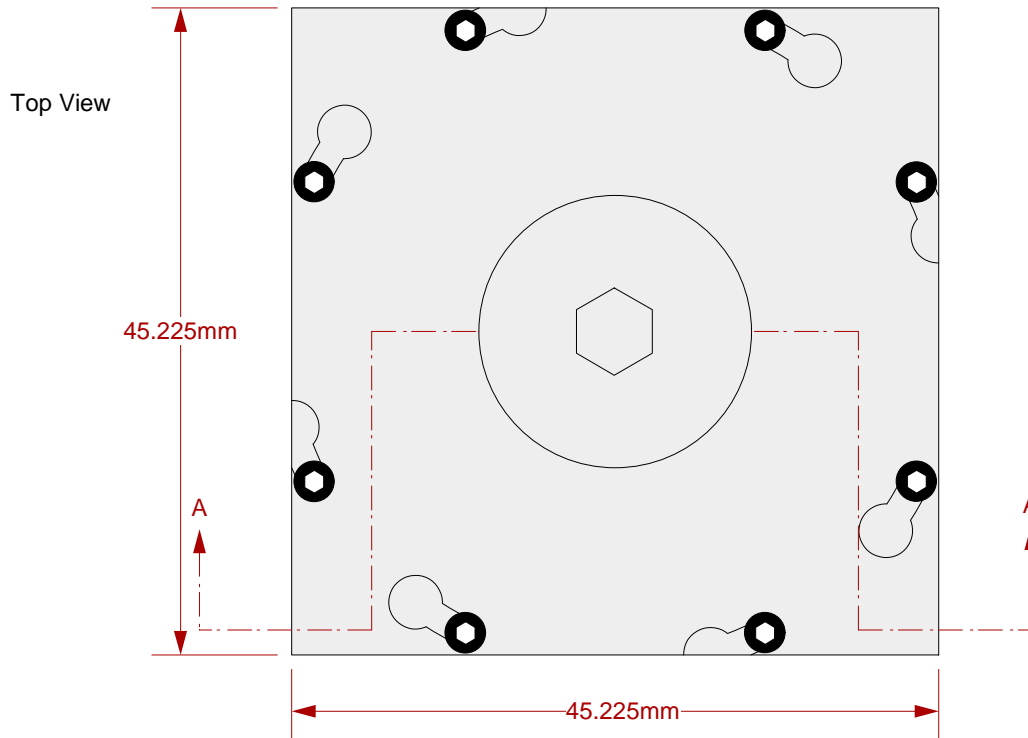

- | | |
|----|--|
| 1 | Socket Lid: Black anodized Aluminum.
Thickness = 2.5mm. |
| 2 | Socket base: Black anodized Aluminum.
Thickness = 7.5mm. |
| 3 | Compression Plate: Black anodized Aluminum.
Thickness = 4.0mm. |
| 4 | Compression screw: Clear anodized Aluminum.
Thickness = 5mm, Hex socket = 5mm. |
| 5 | Elastomer: 40 micron dia gold plated brass filaments arranged symmetrically in a silicone rubber (63.5 degree angle).
Thickness = 0.75mm. |
| 6 | Elastomer Guide: Cirlex or equivalent.
Thickness = 0.725mm. |
| 7 | Ball Guide: Kapton polyimide. |
| 8 | Socket base screw: Socket head cap, alloy steel with black oxide finish, 0-80 fine thread , 12.7mm long. |
| 9 | Socket lid screw: Shoulder screw, 18-8 SS, 0-80 fine thread. |
| 10 | Insulation Plate: FR4/G10, Thickness = 1.59mm. |
| 11 | Backing Plate: Black anodized Aluminum.
Thickness = 6.35mm. |

SG-BGA-6205 Drawing

Status: Released

Scale: -

Rev: B



© 2006 IRONWOOD ELECTRONICS, INC.
11351 Rupp Drive, Suite 400, Burnsville, MN 55337
Tele: (952) 229-8200
www.ironwoodelectronics.com

Drawing: J. Glab

Date: 10/30/06

File: SG-BGA-6205 Dwg

Modified: 7/21/09

All tolerances: ± 0.125 mm (unless stated otherwise). Materials and specifications are subject to change without notice.

***Note: BGA pattern is not symmetrical with respect to the mounting holes.**

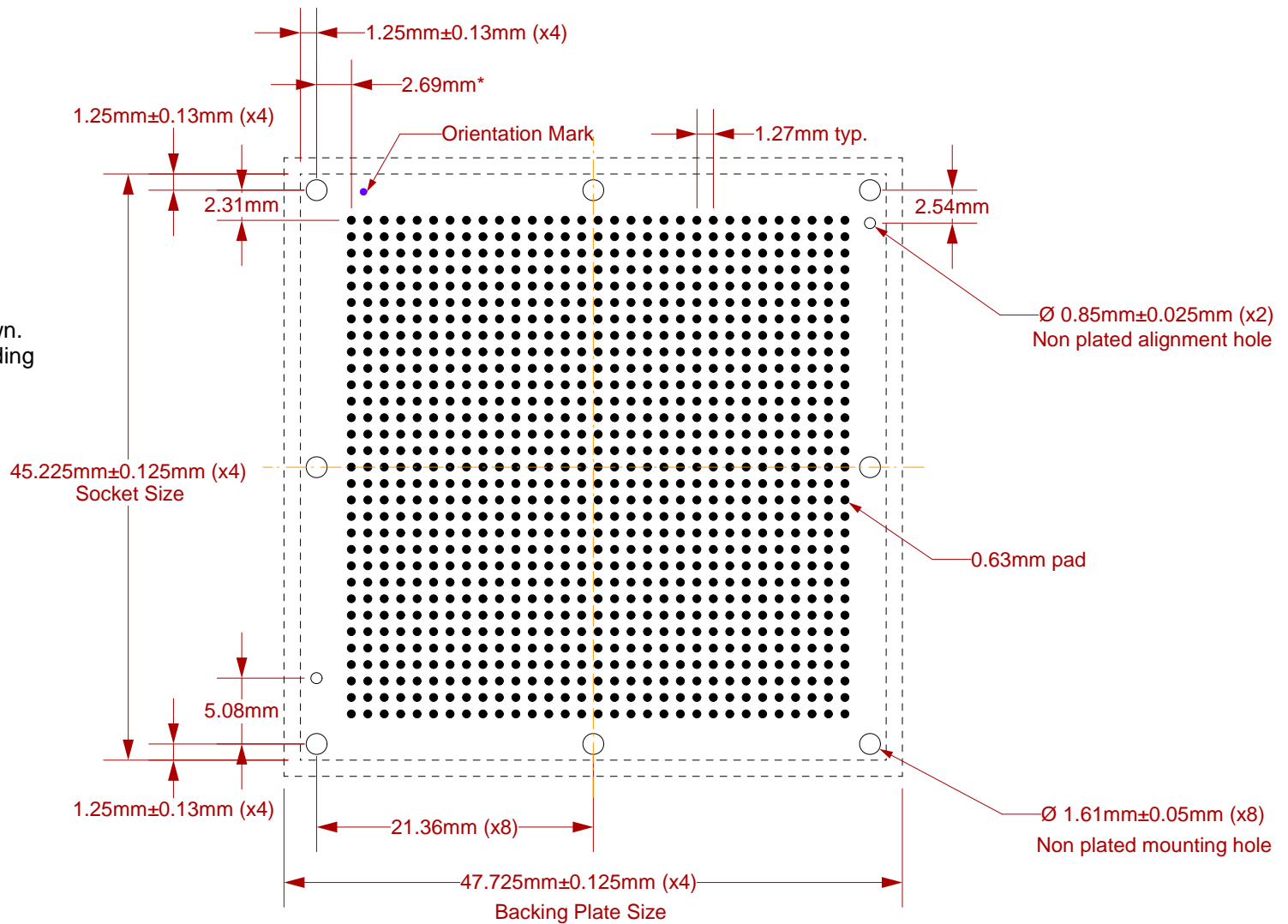

Note: Full BGA pattern shown.
Please adjust pattern according
to individual requirements.

Target PCB Recommendations

Total Thickness: 2.4mm min.
Plating: Gold or Solder finish.
PCB Pad Height: Same or higher than solder mask.

NOTE: Steel backing plate may be required based on end user's application.

Recommended PCB Layout Tolerances: $\pm 0.025\text{mm}$ [$\pm 0.001''$] unless stated otherwise.

 <p>SG-BGA-6205 Drawing</p> <p>© 2006 IRONWOOD ELECTRONICS, INC. 11351 Rupp Drive, Suite 400, Burnsville, MN 55337 Tele: (952) 229-8200 www.ironwoodelectronics.com</p>	Status: Released	Scale: 2:1	Rev: B
	Drawing: J. Glab		Date: 10/30/06
	File: SG-BGA-6205 Dwg		Modified: 7/21/09

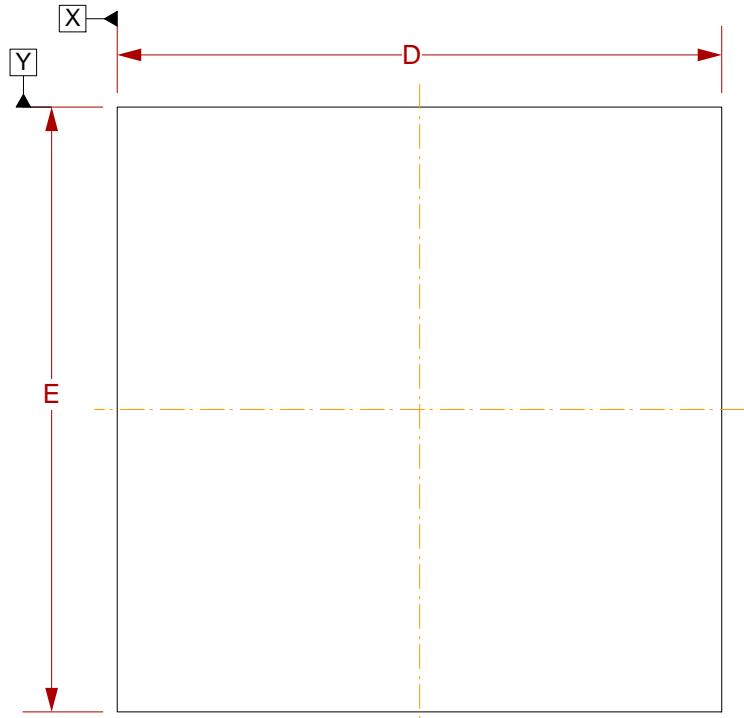

Top View

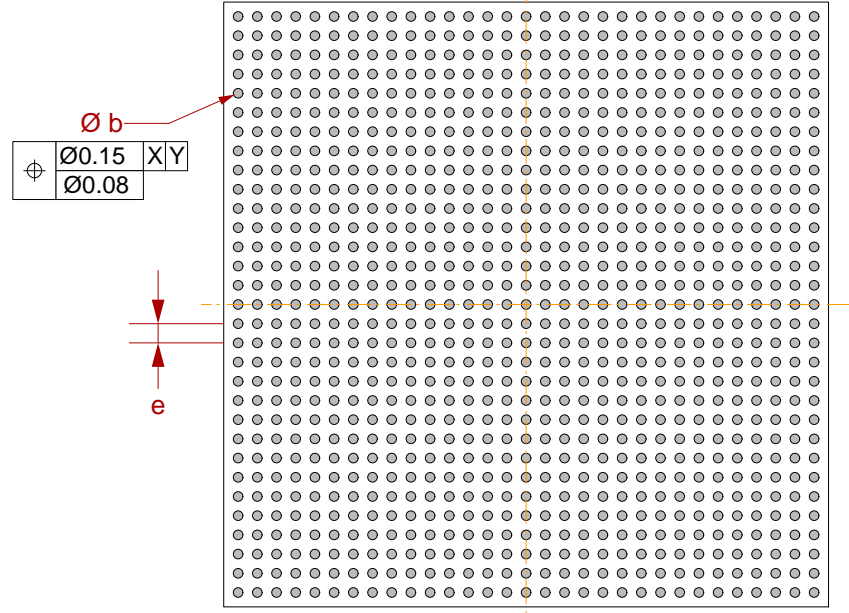

Bottom View



Side View

- 1 Dimensions are in millimeters.
- 2 Interpret dimensions and tolerances per ASME Y14.5M-1994.
- 3 Dimension b is measured at the maximum solder ball diameter, parallel to datum plane Z.
- 4 Datum Z (seating plane) is defined by the spherical crowns of the solder balls.
- 5 Parallelism measurement shall exclude any effect of mark on top surface of package.

DIM	MIN	MAX
A		3.50
A1	0.30	
b		0.90
D/E	40.00 BSC	
e	1.27 BSC	

Array: 31x31

 <p>© 2006 IRONWOOD ELECTRONICS, INC. 11351 Rupp Drive, Suite 400, Burnsville, MN 55337 Tele: (952) 229-8200 www.ironwoodelectronics.com</p>	SG-BGA-6205 Drawing	Status: Released	Scale: -	Rev: B
	Drawing: J. Glab	Date: 10/30/06		
	File: SG-BGA-6205 Dwg	Modified: 7/21/09		

Top View

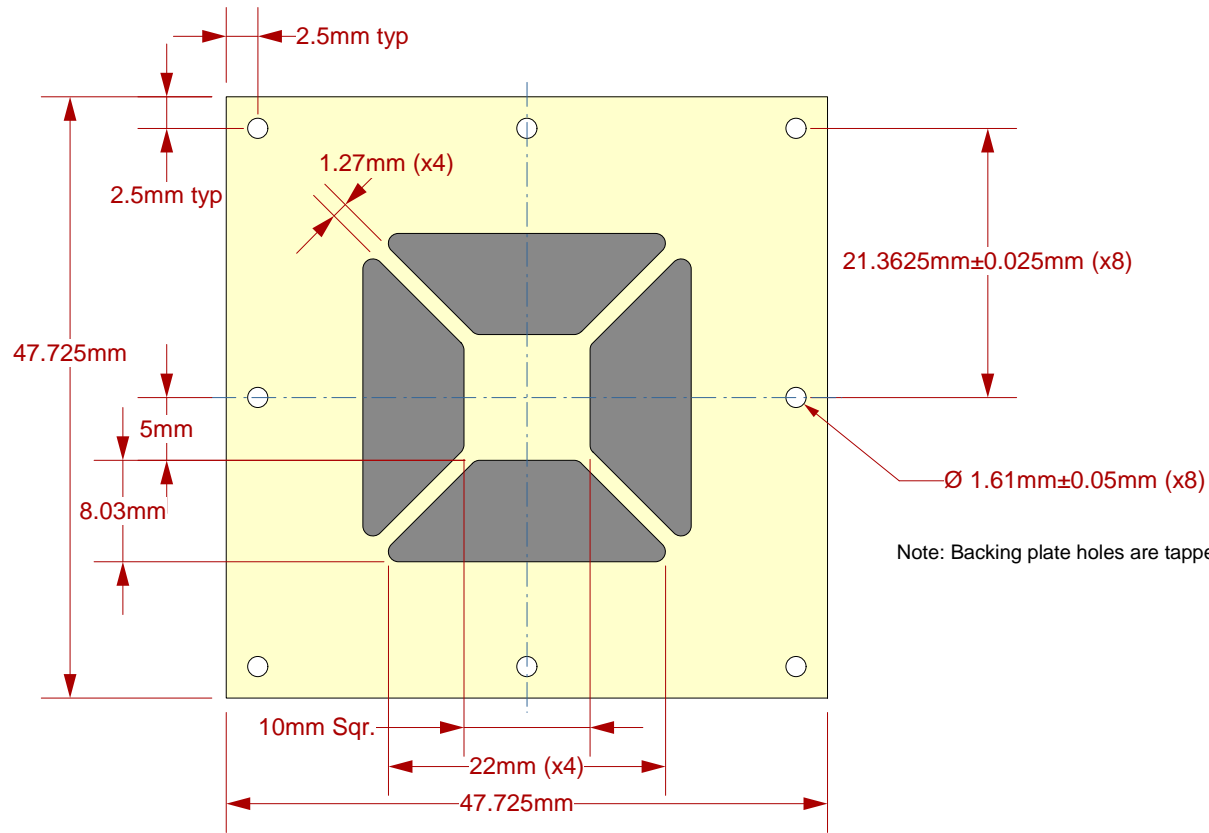

Side View

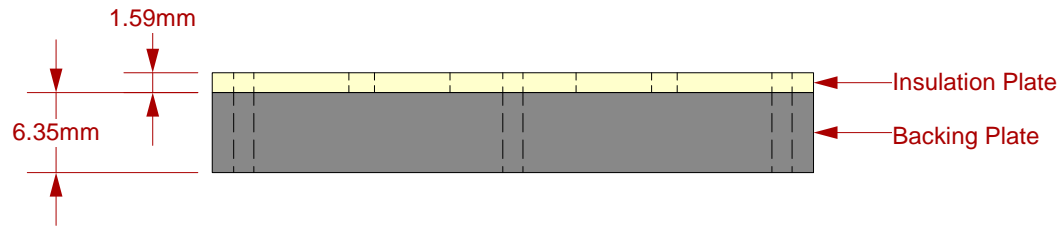

Description: Insulation Plate and Backing Plate.

SG-BGA-6205 Drawing		Status: Released	Scale: -	Rev: B
 <p>© 2006 IRONWOOD ELECTRONICS, INC. 11351 Rupp Drive, Suite 400, Burnsville, MN 55337 Tele: (952) 229-8200 www.ironwoodelectronics.com</p>	Drawing: J. Glab		Date: 10/30/06	
	File: SG-BGA-6205 Dwg		Modified: 7/21/09	

All dimensions are in mm.
All tolerances are +/- 0.125mm.
(Unless stated otherwise)