

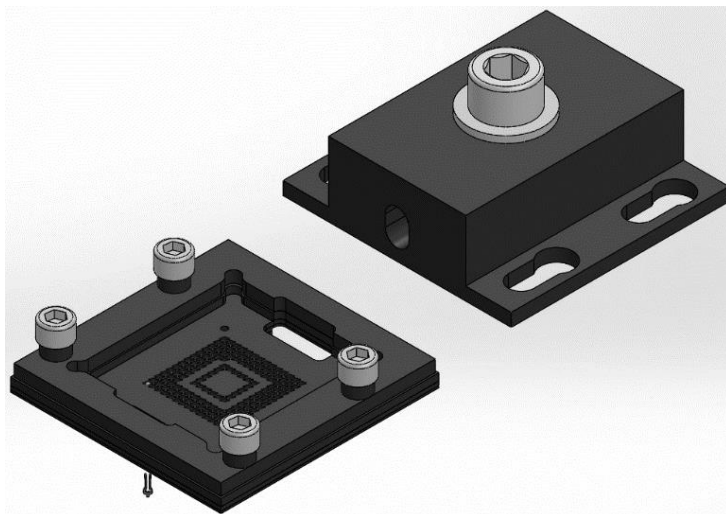

## Grypper Y

High Performance Near Zero Footprint Sockets for 0.40 + pitch devices. New Y contact is less aggressive to device solder ball allowing multiple insertions of the same device. Lower insertion - positive retention with spring bias Lid



Ironwood Electronics new Grypper Y contact is design to work with BGA devices with solder balls/bumps with no equator or small exposure where the standard Grypper cannot reliable hold onto the solder ball. The Y shape, working with the lid, allows reliable contact and ensures device retention in high vibration application. Lower forces, < 25 grams, makes insertion easier too and the less aggressive contacting allows 20-40 insertions of the same device. The Lid can be configured to include heat sinking. The Y contact designs cover BGA devices from 0.40 pitch and larger and the short electrical length has superior electrical performance.

### FEATURES AND BENEFITS

Near Zero PCB footprint	The Grypper Y socket footprint is only 1 mm larger than the DUT. Typically this footprint will fit into any end application allowing the Grypper Y socket to be directly reflowed into the same location as the device.
Soft contacting	The Y shape results in a wiping action and less aggressive contact to the solder ball which allows multiple insertions of the same device. The removal force is extremely low at ~3 grams / contact.
Lid	The Lid is used to insert the device and assures excellent contact. The screw on the top releases the press onto the device so the forces are controlled and balance to each application. Different materials can be design in the lid to act as a heat sink.
Excellent signal performance	The Short signal path and two points of contact, achieves low CRES and low insertion loss.

### METHODOLOGY



Cross section view of test socket and BGA device

CONTACT

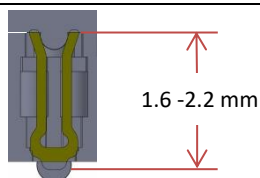

Minimum Pitch (mm)	Ball Diameter (mm)	Contact Length (mm)
<b>0.80</b>	<b>0.55</b>	<b>2.2</b>
0.80	0.50	2.2
<b>0.80</b>	<b>0.45</b>	<b>2.2</b>
0.65	0.40	1.6
<b>0.50</b>	<b>0.35</b>	<b>1.6</b>
<b>0.50</b>	<b>0.30</b>	<b>1.6</b>
<b>0.40</b>	<b>0.25</b>	<b>1.6</b>

Bold listing above tooled / available with 3-4 weeks delivery- others under development -lead time 6-8 + weeks

ELECTRICAL SPECIFICATIONS

Measured result listed below for 0.8 pitch 0.55 solder ball contact configuration  
Contact Ironwood for RF simulation and model reports, HFSS and S parameter files.

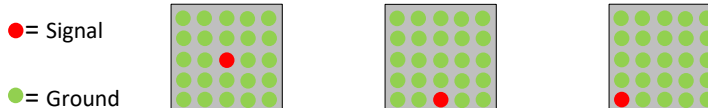

	Field	Edge	Corner
Loop inductance	0.540 nH	0.630 nH	0.720 nH
Mutual inductance	0.139 nH	0.141 nH	0.161 nH
Capacitance	0.227 pF	0.218 pF	0.209 pF
Mutual Capacitance	0.046 pF	0.050 pF	0.640 pF
S21 Insertion loss (-1 dB)	>40 GHz	>40 GHz	16.1 GHz
S11 Return loss (-20 dB)	>40 GHz	13.2 GHz	8.6 GHz
S41 Crosstalk (GSSG)	N/A	-20dB @>40 GHz	N/A
Impedance	53.6 Ω	56.2 Ω	60.1 Ω
Time Delay	12.7 ps	12.9 ps	13.5ps
Current Carrying Capacity	6.4 Amps DC @ 20 <sup>o</sup> C Rise		
CRES	<50 mΩ	<50 mΩ	<50 mΩ

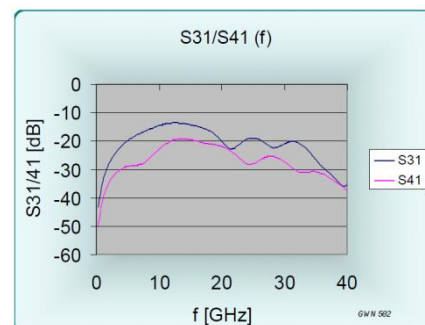
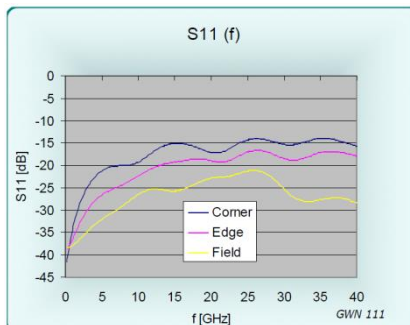
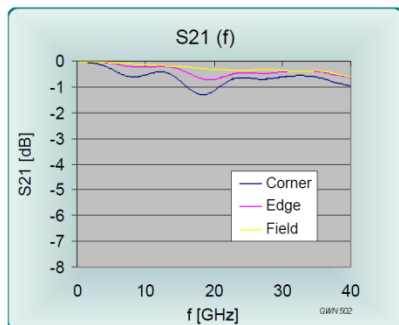

MECHANICAL SPECIFICATIONS

Contact Life	200+ Insertions
Insertion Force	~20-25 grams / contact
Contact Length	1.6 -2.2 mm - See Contact Matrix

MATERIAL SPECIFICATIONS

Contact	Copper alloy (Cu)
Contact Plating	Gold (Au) over Nickel (Ni)
Housing	Polyimide (Cirlex®)
Environmental	-55°C to 155°C

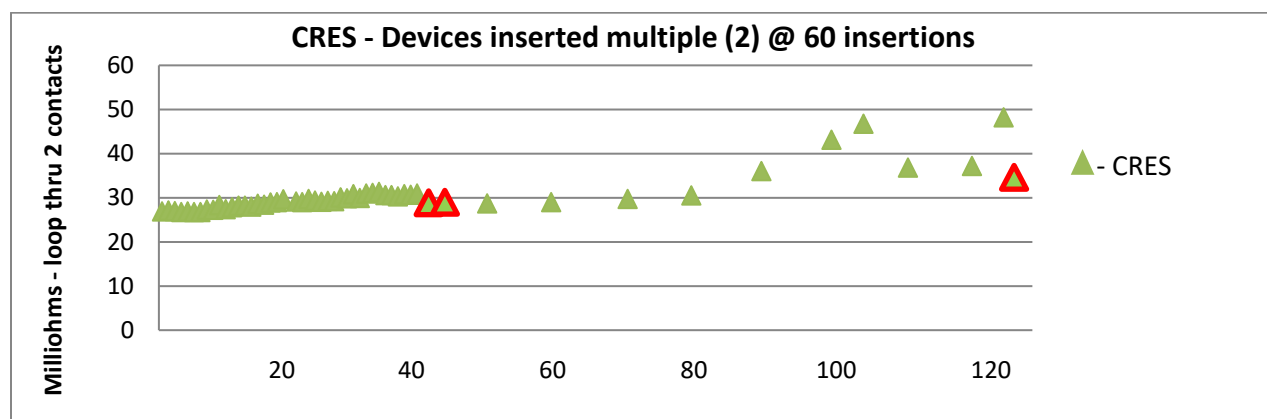

Above 2 devices inserted 60 times - very stable up to 40 each - virgin devices insert at 41 42 and 120

SOCKET / LID OVERVIEW

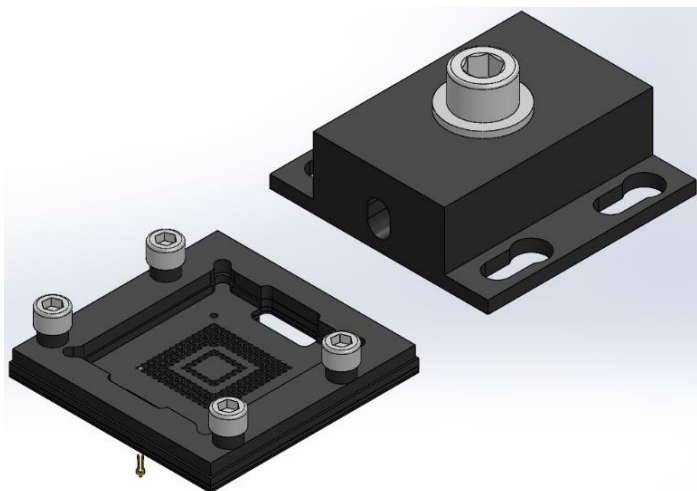

Grypper Y socket attaches the same as the Standard Grypper, G80 and G40 product through a reflow process. The Lid (shown left) locks to the shoulder screws in the socket frame. Once in place the screw on the top is turned counter-clockwise which released the press onto the device. This screw can be left loose or removed

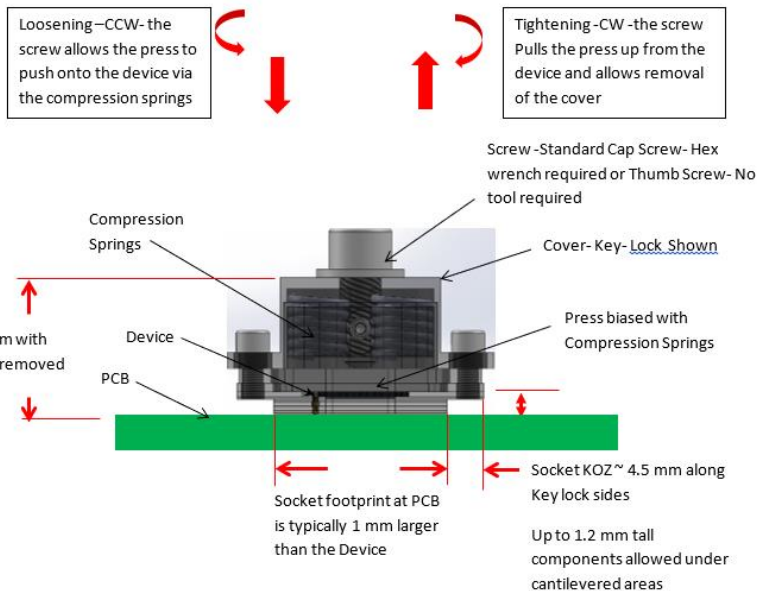

The example above shows a typical stack up of the lid. Optional designs for the lids are available that can be bolted to the socket body. Different designs have advantages and disadvantages based on the end application requirements; keep out zone (KOZ) considerations and nearby component heights. Ironwood can assist on your application to define the best socket and lid combination to meet your needs.

SOCKET CONFIGURATIONS/ OPTIONS

The sockets available with and without solder balls. Socket without solder ball use a stencil to apply the proper amount of solder paste for reflow/ attachment. Socket with solder ball (SAC305 or Eutectic available) attach/reflow to the PCB using the same process used for BGA device attachment

Stencil for socket attachment that do not have solder balls

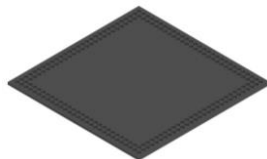

Sockets with and without solder balls

