

GHz BGA Socket - Direct mount, solderless

Top View

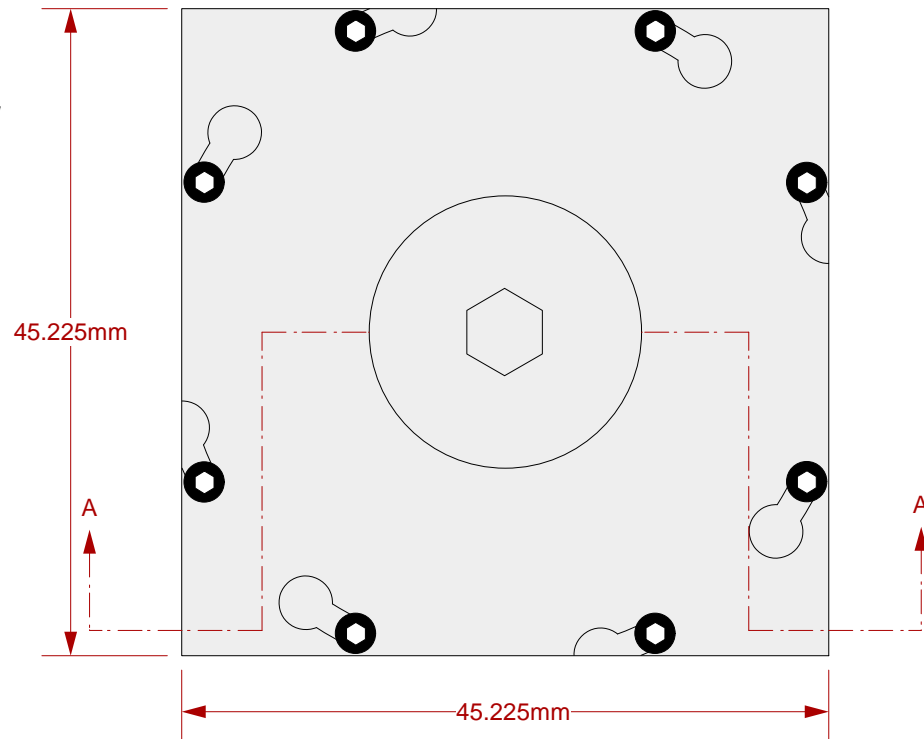

Features

- Directly mounts to target PCB (needs tooling holes) with hardware.
- High speed, reliable Elastomer connection
- Minimum real estate required
- Compression plate distributes forces evenly
- Ball guide prevents over compression of elastomer
- Easily removable swivel socket lid

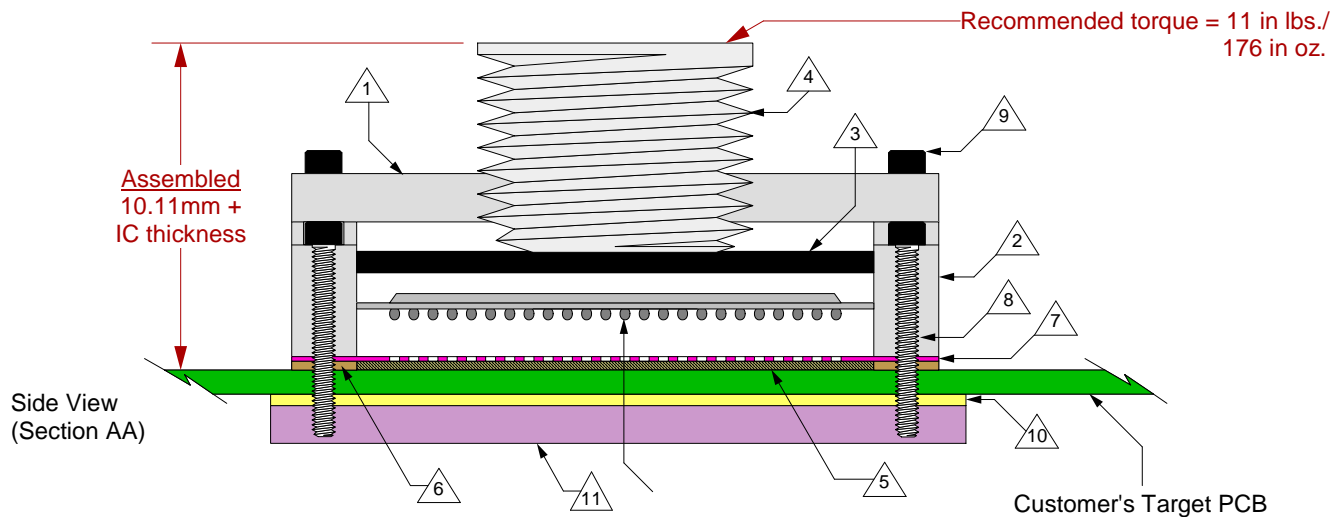

- △ 1 Socket Lid: Black anodized Aluminum. Thickness = 2.5mm.
- △ 2 Socket base: Black anodized Aluminum. Thickness = 6.5mm.
- △ 3 Compression Plate: Black anodized Aluminum. Thickness = 4.0mm.
- △ 4 Compression screw: Clear anodized Aluminum. Thickness = 5mm, Hex socket = 5mm.
- △ 5 Elastomer: 40 micron dia gold plated brass filaments arranged symmetrically in a silicone rubber (63.5 degree angle). Thickness = 0.75mm.
- △ 6 Elastomer Guide: Cirlex or equivalent. Thickness = 0.725mm.
- △ 7 Ball Guide: Kapton polyimide.
- △ 8 Socket base screw: Socket head cap, alloy steel with black oxide finish, 0-80 fine thread, 12.7mm long.
- △ 9 Socket lid screw: Shoulder screw, 18-8 SS, 0-80 fine thread.
- △ 10 Insulation Plate: FR4/G10, Thickness = 1.59mm.
- △ 11 Backing Plate: Black anodized Aluminum. Thickness = 6.35mm.

SG-BGA-6039 Drawing

Status: Released

Scale: -

Rev: F



© 2009 IRONWOOD ELECTRONICS, INC.
11351 Rupp Drive, Suite 400, Burnsville, MN 55337
Tele: (952) 229-8200
www.ironwoodelectronics.com

Drawing: H. Hansen

Date: 3/13/02

File: SG-BGA-3039 Dwg

Modified: 7/09/09, AE

All tolerances: $\pm 0.125\text{mm}$ (unless stated otherwise). Materials and specifications are subject to change without notice.

***Note: BGA pattern is not symmetrical with respect to the mounting holes.**

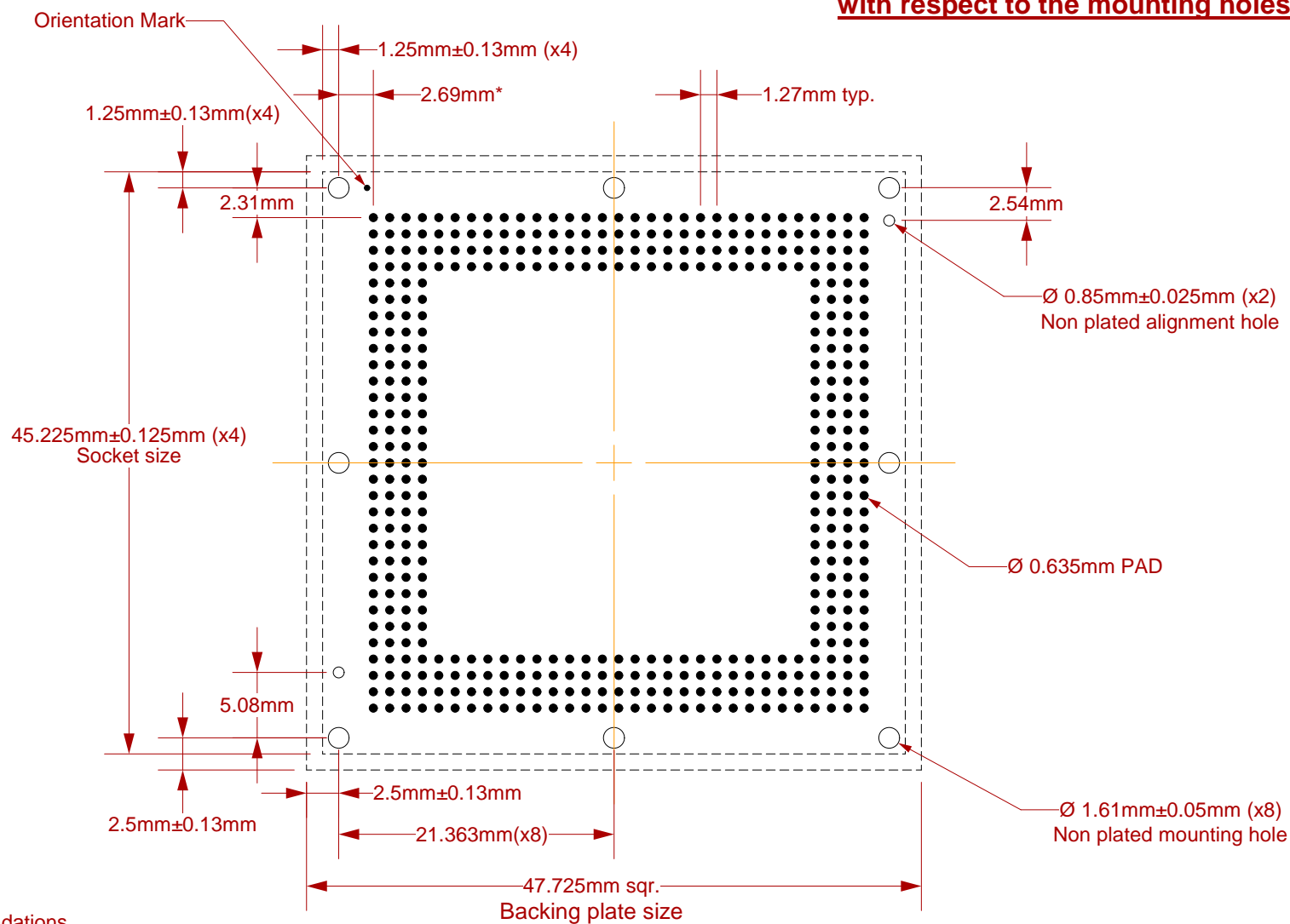

Target PCB Recommendations

Total thickness: 2.4mm min.
Plating: Gold or Solder finish
PCB Pad height: Same or higher than solder mask

NOTE: Steel backing plate may be required based on end user's application

Recommended PCB Layout Tolerances: ±0.025mm [±0.001"] unless stated otherwise.

 <p>© 2009 IRONWOOD ELECTRONICS, INC. 11351 Rupp Drive, Suite 400, Burnsville, MN 55337 Tele: (952) 229-8200 www.ironwoodelectronics.com</p>	<p>SG-BGA-6039 Drawing</p>		<p>Status: Released</p>	<p>Scale: 2:1</p>	<p>Rev: F</p>
	<p>Drawing: H. Hansen</p>		<p>Date: 3/13/02</p>		
	<p>File: SG-BGA-6039 Dwg</p>		<p>Modified: 7/09/09, AE</p>		

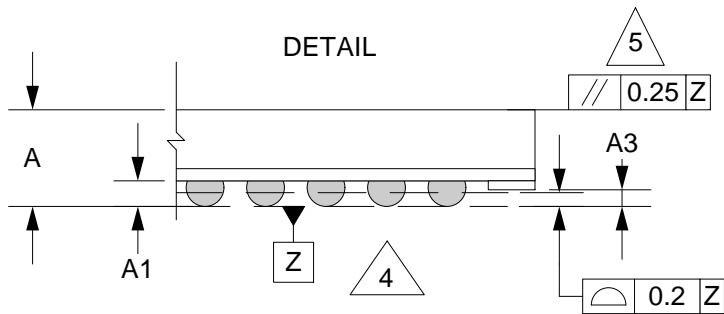
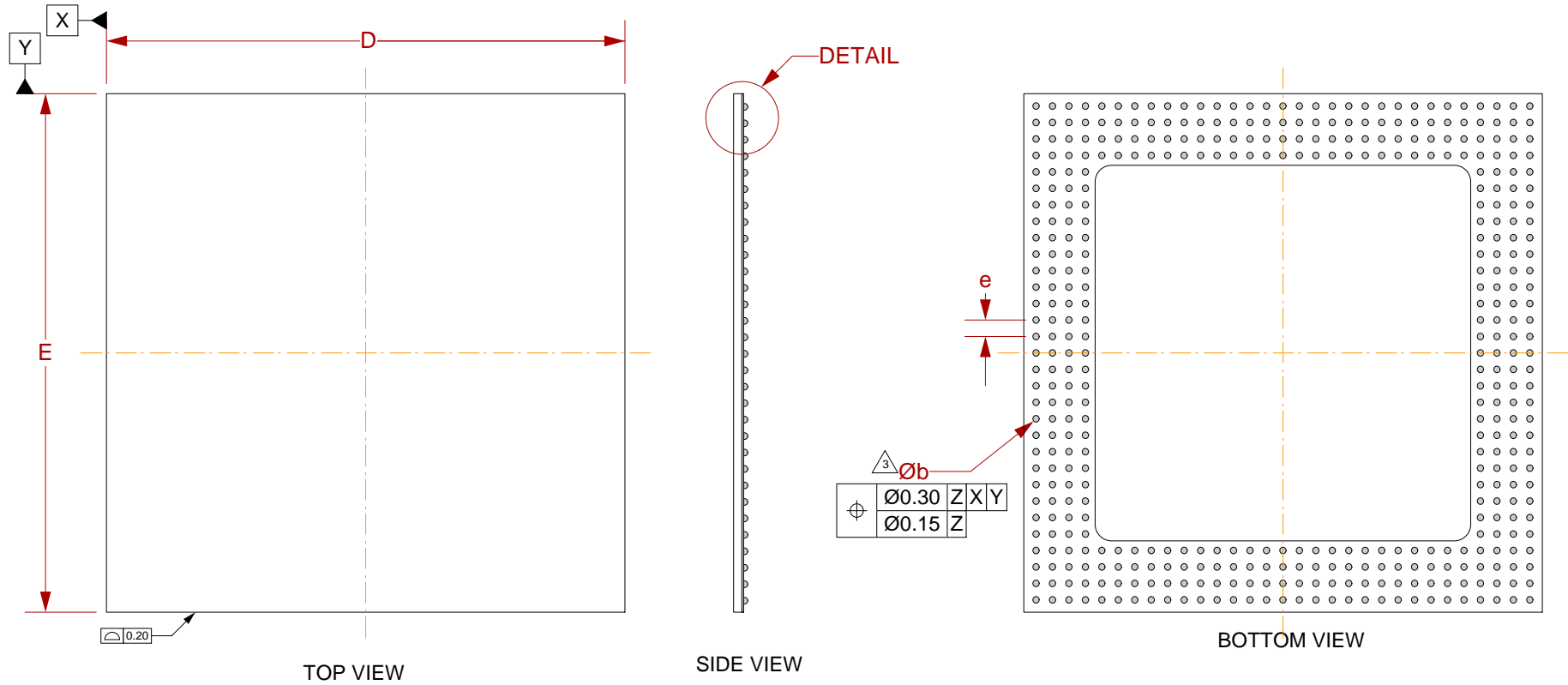

1. Dimensions are in millimeters.
2. Interpret dimensions and tolerances per ASME Y14.5M-1994.
3. Dimension b is measured at the maximum solder ball diameter, parallel to datum plane Z.
4. Datum Z (seating plane) is defined by the spherical crowns of the solder balls.
5. Parallelism measurement shall exclude any effect of mark on top surface of package.

DIM	MIN	MAX
A		1.7
A1	0.5	0.7
A3	0.2	
b		0.9
D	40.0 BSC	
E	40.0 BSC	
e	1.27 BSC	

Array: 31x31

 <p>© 2009 IRONWOOD ELECTRONICS, INC. 11351 Rupp Drive, Suite 400, Burnsville, MN 55337 Tele: (952) 229-8200 www.ironwoodelectronics.com</p>	<p>SG-BGA-6039 Drawing</p>	<p>Status: Released</p>	<p>Scale: -</p>	<p>Rev: F</p>
	<p>Drawing: H. Hansen</p>		<p>Date: 3/13/02</p>	
	<p>File: SG-MGA-6039 Dwg</p>		<p>Modified: 7/09/09, AE</p>	

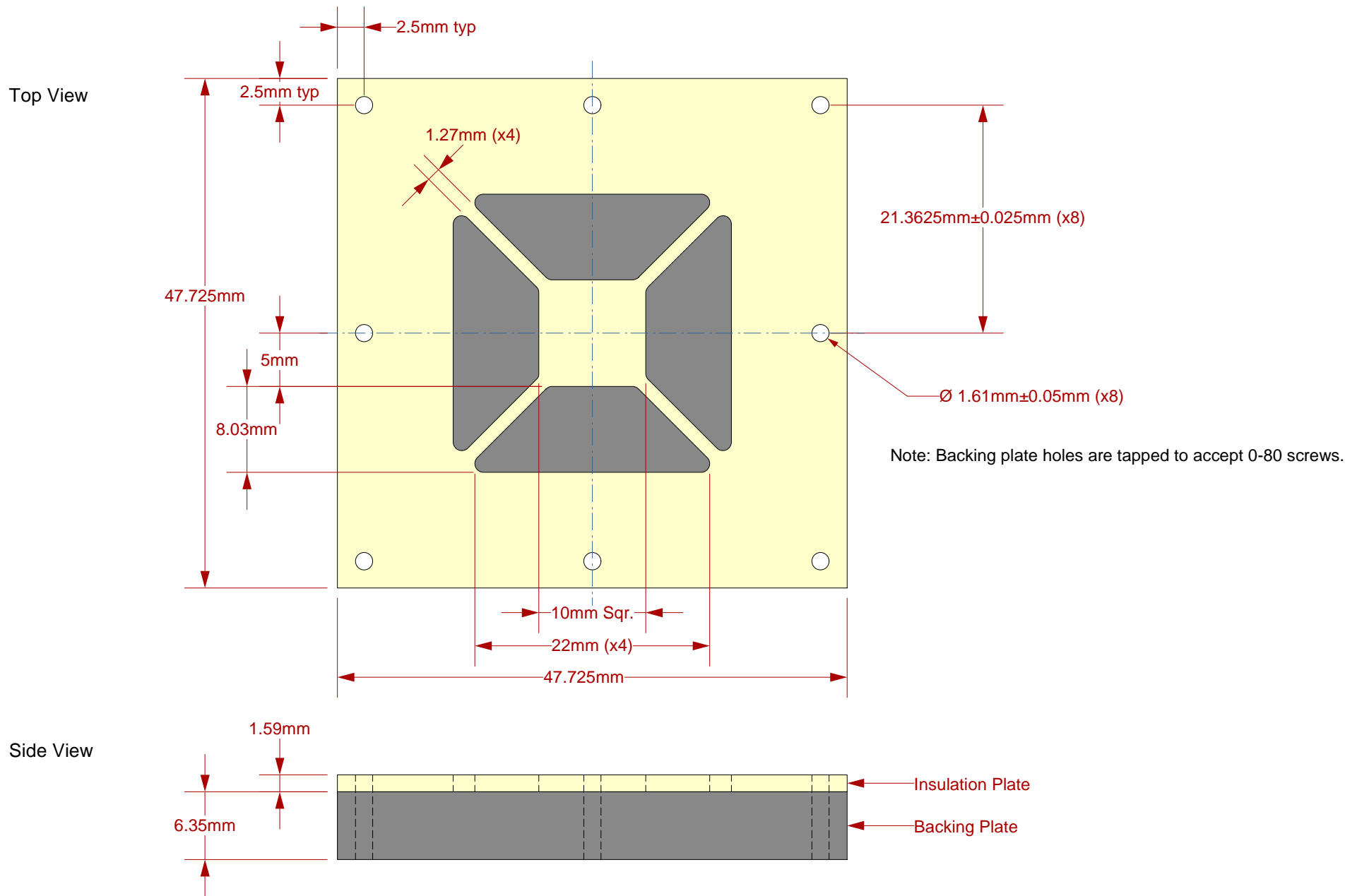

Description: Insulation Plate and Backing Plate

 <p>© 2009 IRONWOOD ELECTRONICS, INC. 11351 Rupp Drive, Suite 400, Burnsville, MN 55337 Tele: (952) 229-8200 www.ironwoodelectronics.com</p>	<p>SG-BGA-6039 Drawing</p>		<p>Status: Released</p>	<p>Scale: -</p>	<p>Rev: F</p>
	<p>Drawing: H. Hansen</p>		<p>Date: 3/13/02</p>		
	<p>File: SG-MGA-6039 Dwg</p>		<p>Modified: 7/09/09, AE</p>		

All dimensions are in mm.
All tolerances are +/- 0.125mm.
(Unless stated otherwise)