

GHz BGA Socket - Epoxy mount, solderless

Features

- Directly mounts to target PCB (needs epoxy) .
- High speed, reliable Elastomer connection
- Minimum real estate required
- Compression plate distributes forces evenly
- Easily removable socket lid

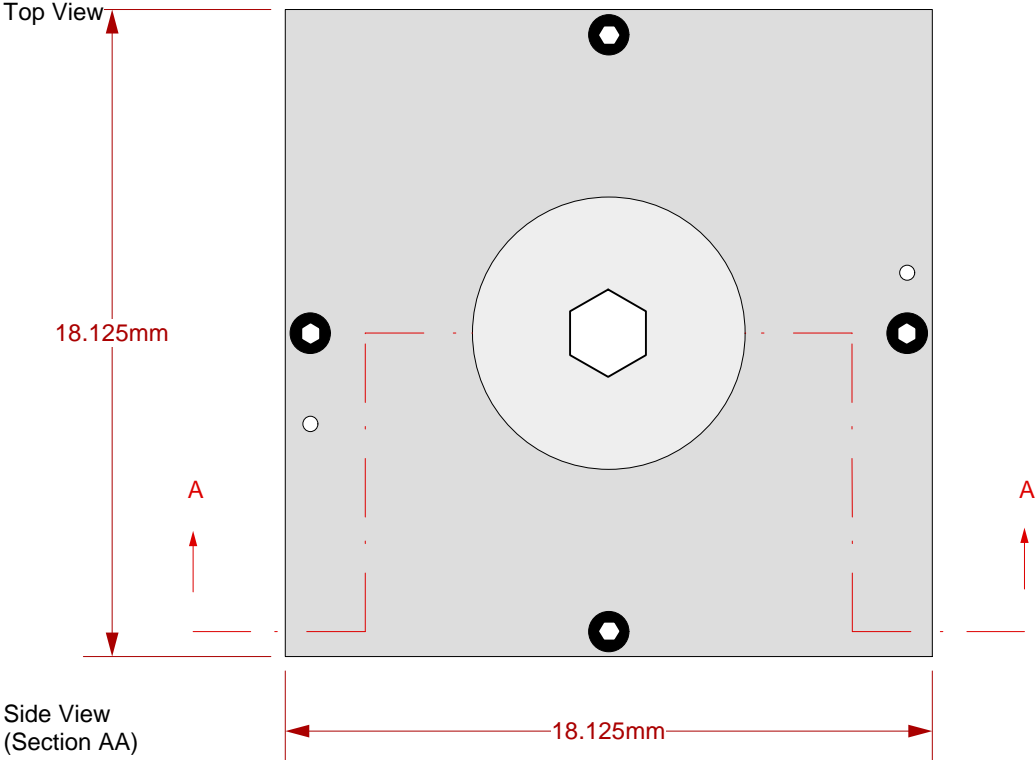

- 1 Socket Lid: Black anodized 6061 Aluminum. Thickness = 2.5mm.
- 2 Socket base: Black anodized 6061 Aluminum. Thickness = 5mm.
- 3 Compression Plate: Black anodized 6061 Aluminum. Thickness = 2.5mm.
- 4 Compression screw: Clear anodized 6061 Aluminum. Thickness = 5mm, Hex socket = 5mm.
- 5 Elastomer: 20 micron dia gold plated brass filaments arranged symmetrically in a silicone rubber (63.5 degree angle). Thickness = 0.5mm.
- 6 Socket lid screw: Socket head cap, Alloy steel with black oxide finish, 0-80 fine thread , 4.76mm long.

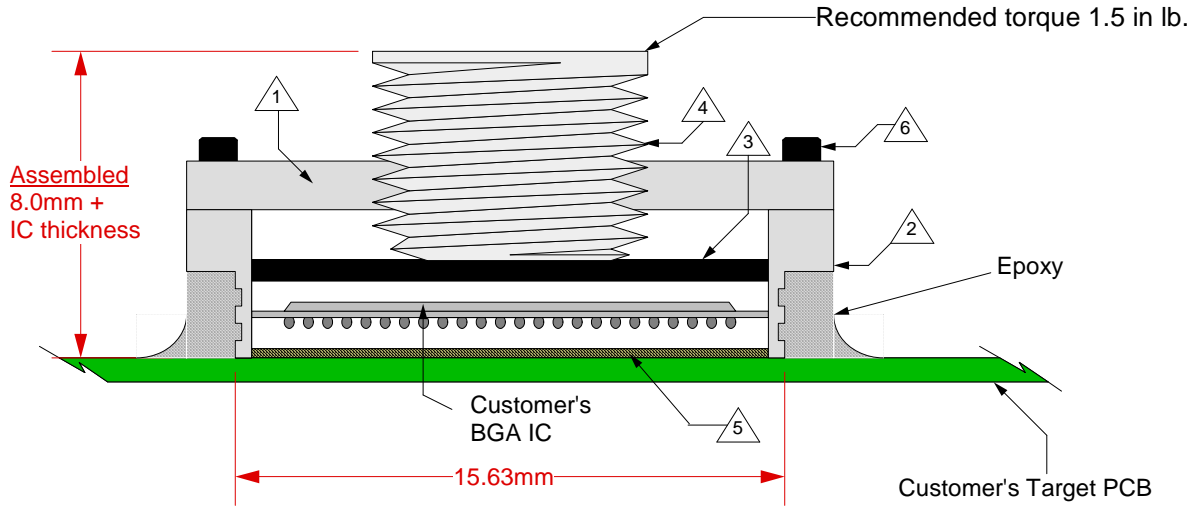

Note: Alignment guide for positioning socket base to target PCB will be supplied.

	SG-BGA-7028 Drawing	Status: Released	Scale: -	Rev: C
	© 2005 IRONWOOD ELECTRONICS, INC. PO BOX 21151 ST. PAUL, MN 55121 Tele: (651) 452-8100 www.ironwoodelectronics.com	Drawing: H. Hansen		Date: 1/10/05
		File: SG-BGA-7028 Dwg	Modified: 07/31/14	

All tolerances: ±0.125mm (unless stated otherwise). Materials and specifications are subject to change without notice.

Recommended PCB Layout
Top View

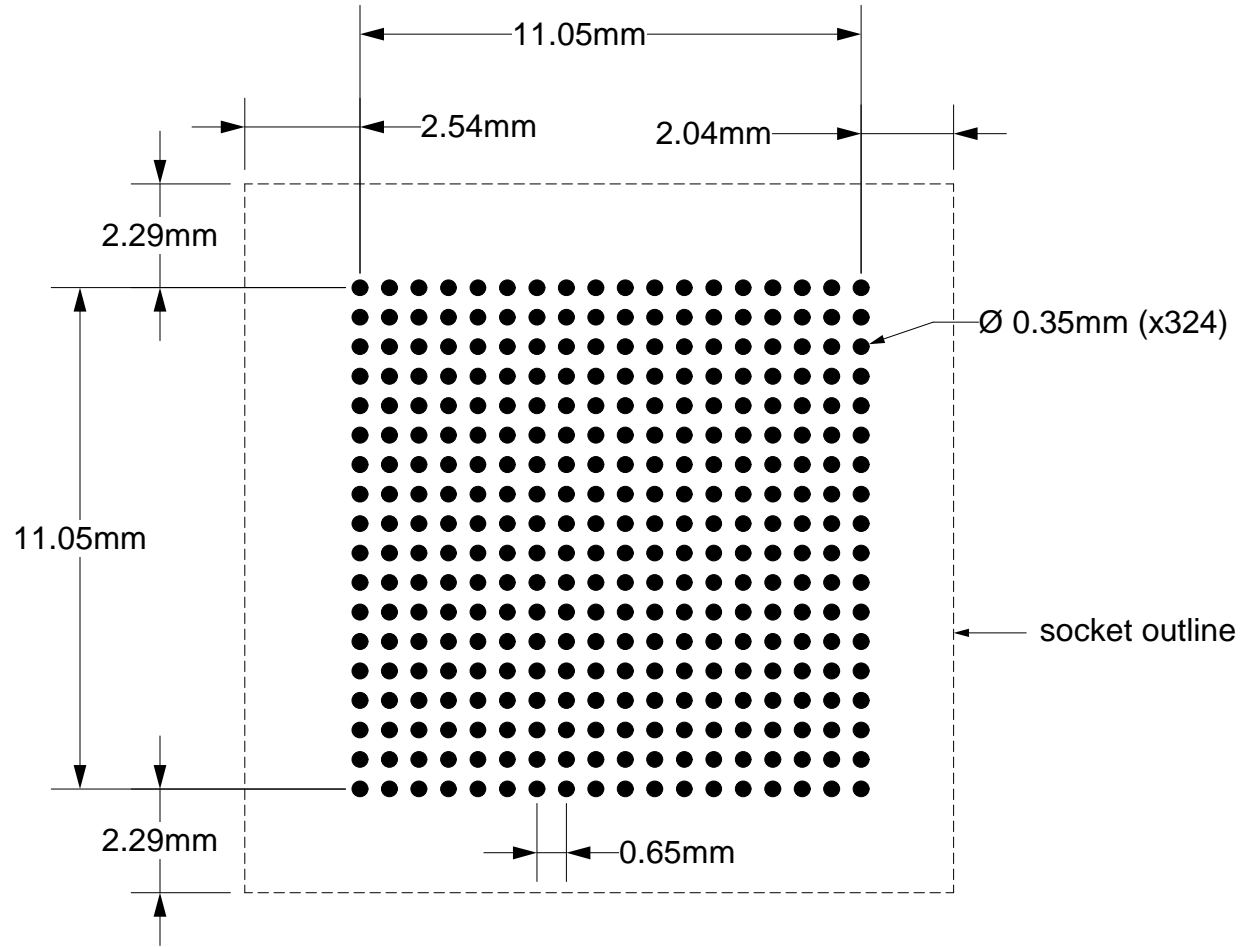

Target PCB Recommendations

- Total thickness: 1.6mm min.
- Plating: Gold or Solder finish
- PCB Pad height: Same or higher than solder mask

Recommended PCB Layout Tolerances: $\pm 0.025\text{mm}$ [$\pm 0.001''$] unless stated otherwise.

<p>SG-BGA-7028 Drawing</p>	<p>Status: Released</p>	<p>Scale: -</p>	<p>Rev: C</p>
 <p>© 2005 IRONWOOD ELECTRONICS, INC. PO BOX 21151 ST. PAUL, MN 55121 Tele: (651) 452-8100 www.ironwoodelectronics.com</p>	<p>Drawing: H. Hansen</p>		<p>Date: 1/10/05</p>
	<p>File: SG-BGA-7028 Dwg</p>		<p>Modified: 07/31/14</p>

PAGE 2 OF 4

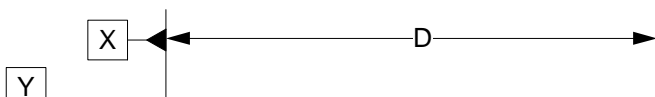

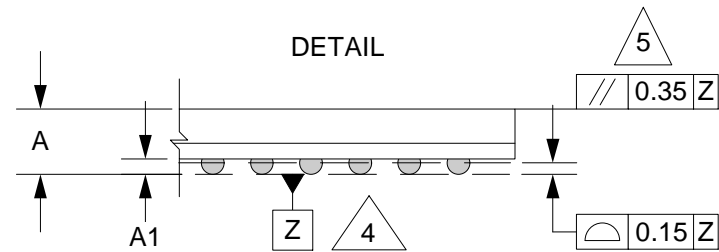
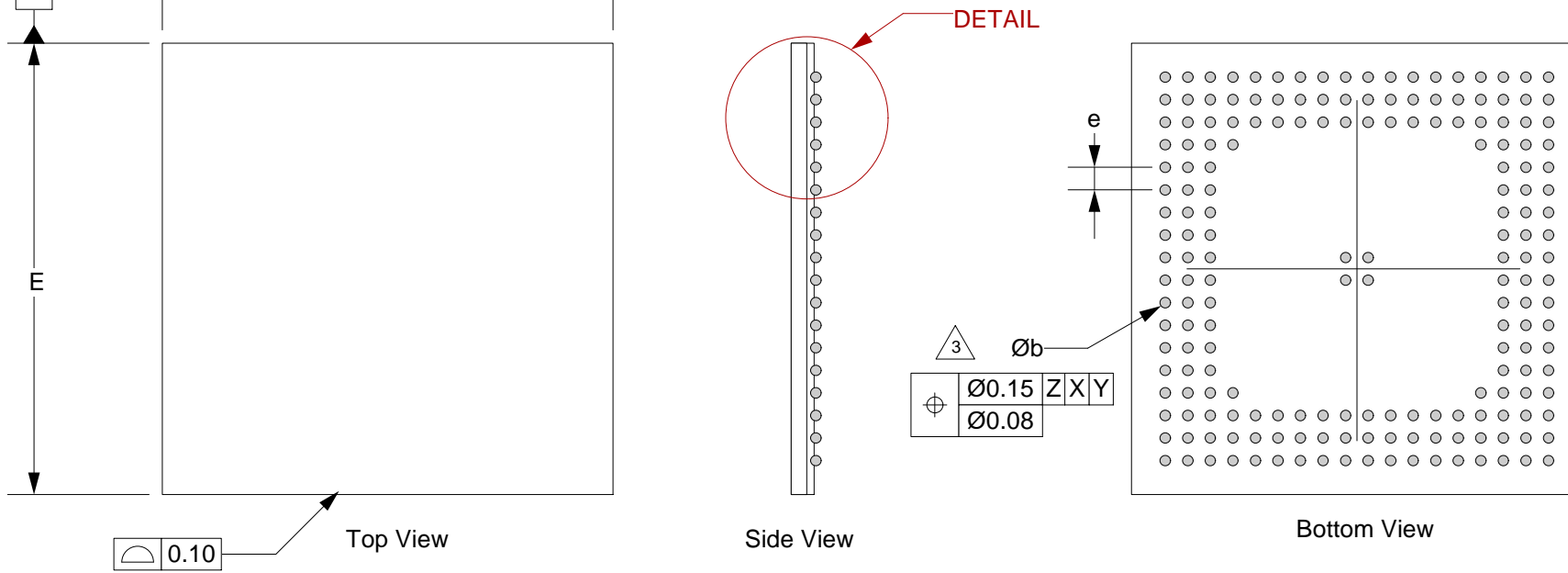

1. Dimensions are in millimeters.
 2. Interpret dimensions and tolerances per ASME Y14.5M-1994.
- Dimension b is measured at the maximum solder ball diameter, parallel to datum plane Z.
 - Datum Z (seating plane) is defined by the spherical crowns of the solder balls.
 - Parallelism measurement shall exclude any effect of mark on top surface of package.

DIM	MIN	MAX
A		0.98
A1	0.17	0.27
b	0.25	0.40
D	13.00 BSC	
E	13.00 BSC	
e	0.65 BSC	

18x18 array

	SG-BGA-7028 Drawing	Status: Released	Scale: -	Rev: C
	© 2005 IRONWOOD ELECTRONICS, INC. PO BOX 21151 ST. PAUL, MN 55121 Tele: (651) 452-8100 www.ironwoodelectronics.com	Drawing: H. Hansen		Date: 1/10/05
		File: SG-BGA-7028 Dwg	Modified: 07/31/14	

PAGE 3 OF 4

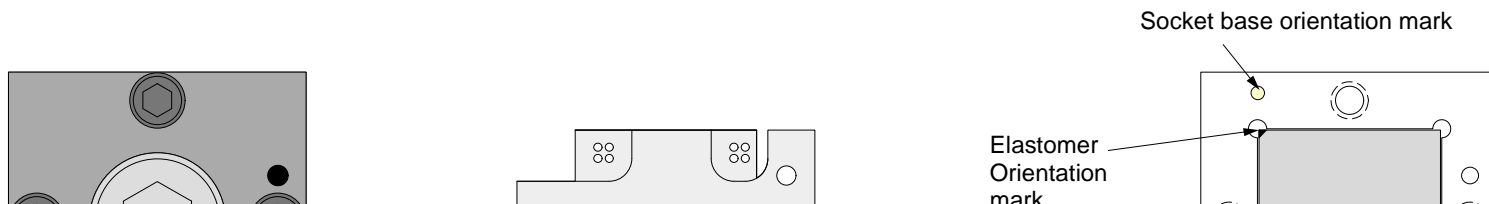

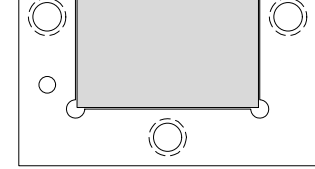
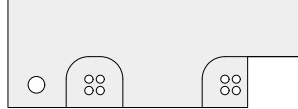
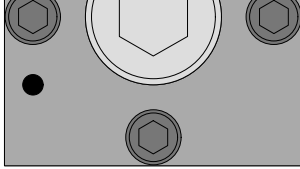

Top View Alignment Plate

When elastomer orientation mark is on upper left corner, side view of elastomer should be

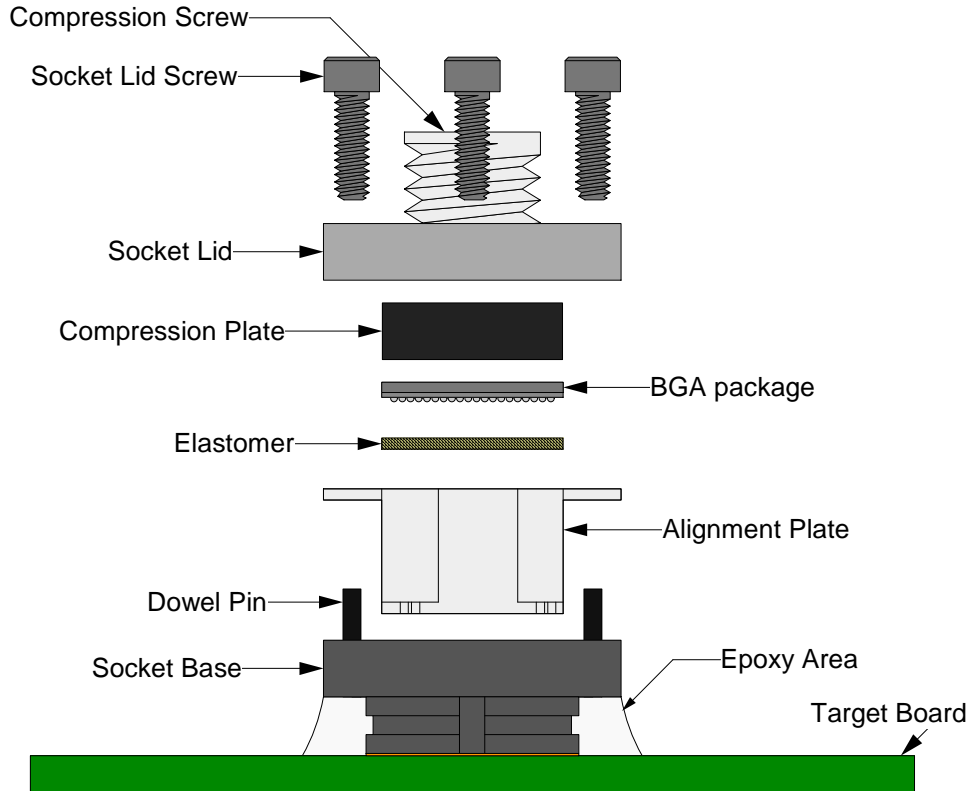
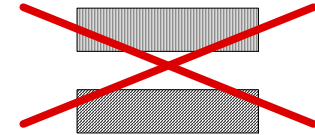

User Instructions:

1. Insert alignment plate onto dowel pins in socket base. Place alignment plate + socket base assembly onto target board.
2. Align holes on alignment plate with four corner pads on target board, hold socket base on to board tightly with finger and put a drop of super glue on each corner. Let it dry, remove the alignment plate, then run a bead of epoxy around socket base and let it cure for 24 hours at room temperature. Recommended epoxy: DP420 (3M brand, 15 min work life). Other equivalent epoxies can be substituted. **Note:** **Do not cure in the oven.**
3. Place elastomer inside the socket base cavity (direction and orientation are critical) as shown above.
4. Place BGA package and compression plate into the socket base cavity.
5. Assemble socket lid onto socket base with socket lid screws.
6. Assemble compression screw into socket lid and apply 1.5 in-lb torque.

	SG-BGA-7028 Drawing	Status: Released	Scale: -	Rev: C
	© 2005 IRONWOOD ELECTRONICS, INC. PO BOX 21151 ST. PAUL, MN 55121 Tele: (651) 452-8100 www.ironwoodelectronics.com	Drawing: H. Hansen		Date: 1/10/05
		File: SG-BGA-7028 Dwg	Modified: 07/31/14	