

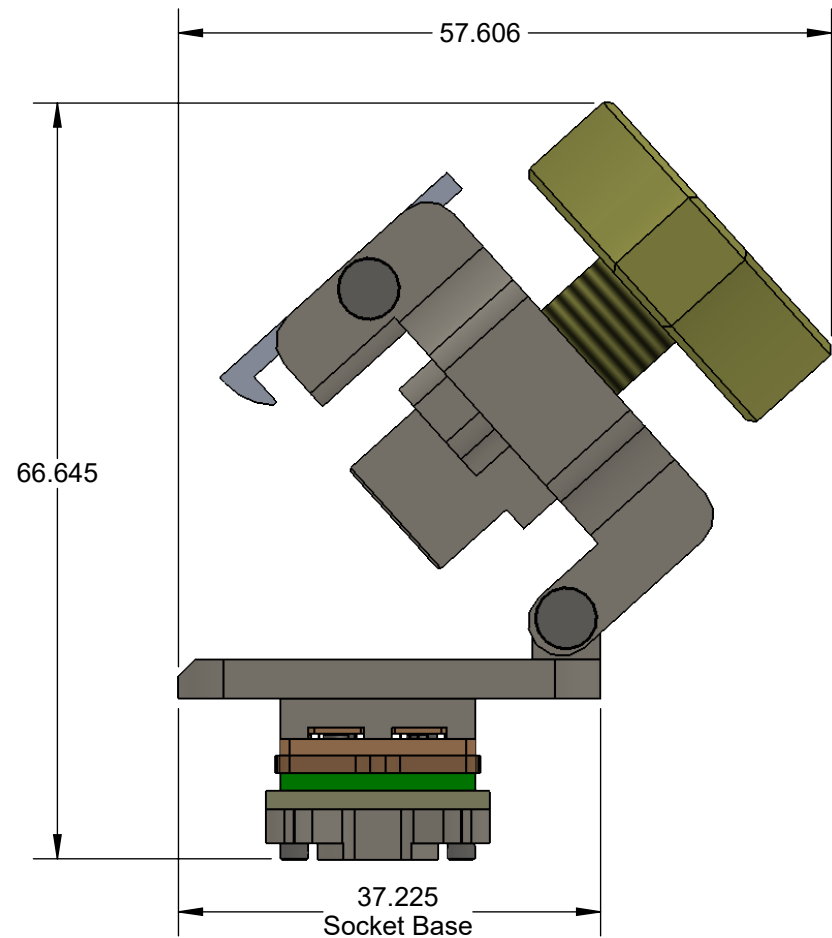

CBT-BGA DIRECT MOUNT, SOLDERLESS SOCKET FOR BURN-IN AND TEST APPLICATIONS

- FEATURES:**
- Wide temperature range (-55C to +180C)
 - High current capability (up to 4A)
 - Excellent signal integrity at high frequencies
 - Low and stable contact resistance for reliable production yield
 - Highly compliant to accommodate wide co-planarity variations
 - Automated probe manufacturing enables low cost and short lead time

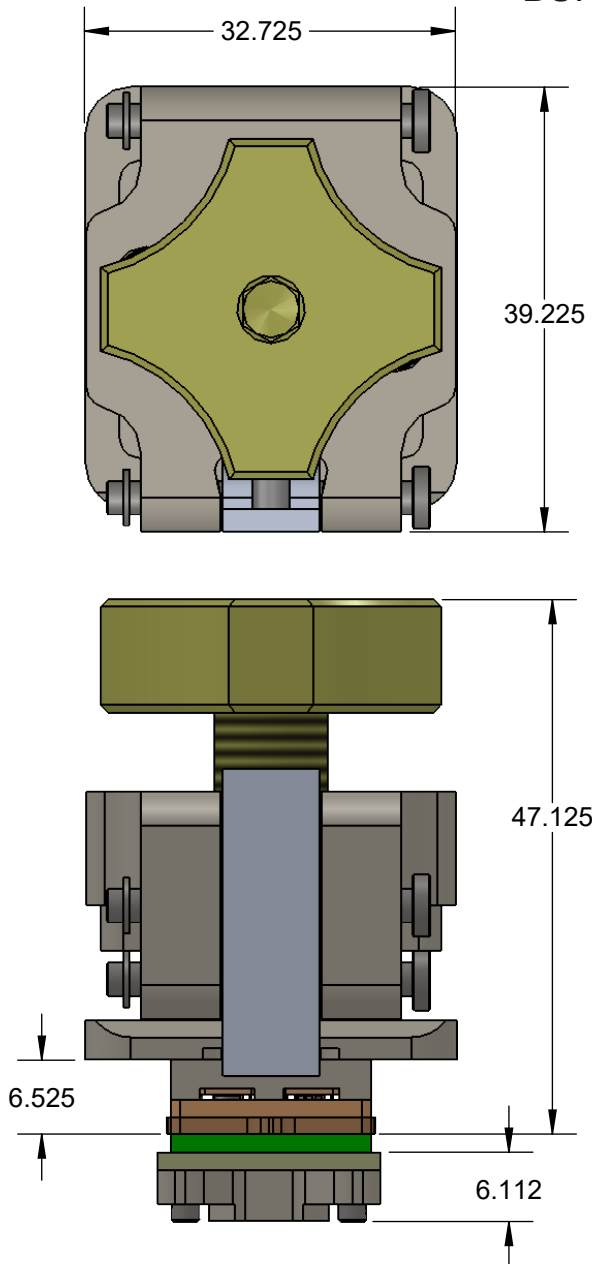

Description: CBT-BGA-6002, 12x12mm,14x14 0.8mm BGA196

Primary dimension units are millimeters, Secondary dimension units are [inches], Weight is in grams.
 Tolerances: Hole diameters $\pm 0.03\text{mm}$ [$\pm 0.001"$], Pitches (from true position) $\pm 0.025\text{mm}$ [$\pm 0.001"$], substrate thickness tolerance $\pm 10\%$, all other tolerances $\pm 0.13\text{mm}$ [$\pm 0.005"$] unless stated otherwise. Materials and specifications are subject to change without notice.

 <p>CBT-BGA-6002 Drawing Ironwood Electronics, Inc. Tele: (800) 404-0204 www.ironwoodelectronics.com</p>	Material: N/A Finish: N/A Weight: 77.65	STATUS: Released	SHEET: 1 OF 5	REV. C
	ENG: E. Smolentseva	DRAWN BY: M. Raske	SCALE: 3:2	DATE: 04/16/2015

***Note: BGA pattern is not symmetrical with respect to the mounting holes. It is shifted by 0.375mm to the right of center.**

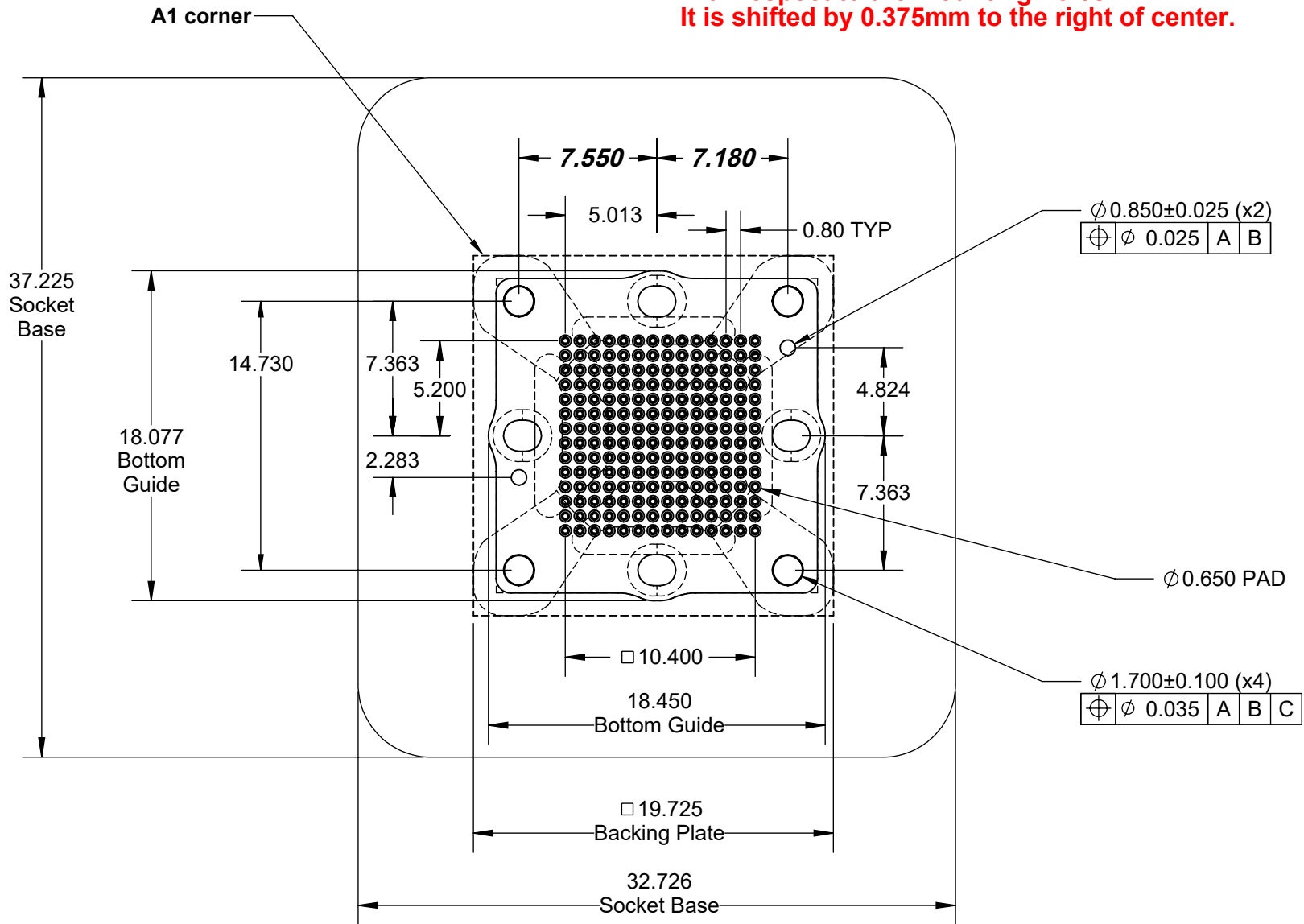

Target PCB Recommendations
Total thickness: 1.6mm min.
Plating: Gold or Solder finish
PCB Pad height: same or higher than solder mask

Description: Recommended PCB Layout

Primary dimension units are millimeters, Secondary dimension units are [inches], Weight is in grams.

Tolerances: Hole diameters $\pm 0.0254\text{mm}$ [$\pm 0.001"$], Pitches (from true position) $\pm 0.0762\text{mm}$ [$\pm 0.003"$], substrate thickness tolerance $\pm 10\%$, all other tolerances $\pm 0.127\text{mm}$ [$\pm 0.005"$] unless stated otherwise. Materials and specifications are subject to change without notice.

 CBT-BGA-6002 Drawing Ironwood Electronics, Inc. Tele: (800) 404-0204 www.ironwoodelectronics.com	Material: N/A Finish: N/A Weight: 77.65	STATUS: Released ENG: E. Smolentseva FILE: CBT-BGA-6002 Dwg	SHEET: 2 OF 5 DRAWN BY: M. Raske DATE: 04/16/2015	REV. C SCALE: 3:1

Ironwood Package Code: BGA144L

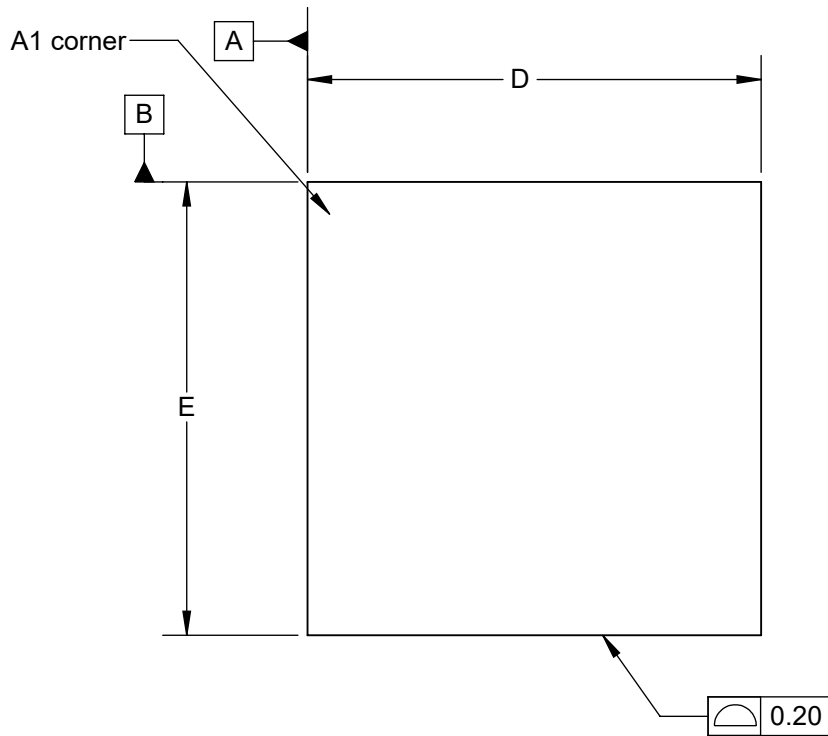

TOP VIEW

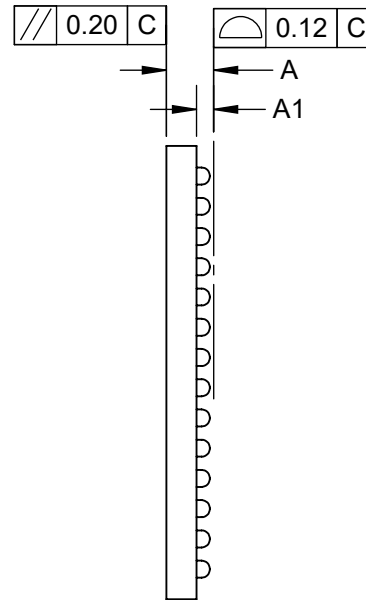

SIDE VIEW

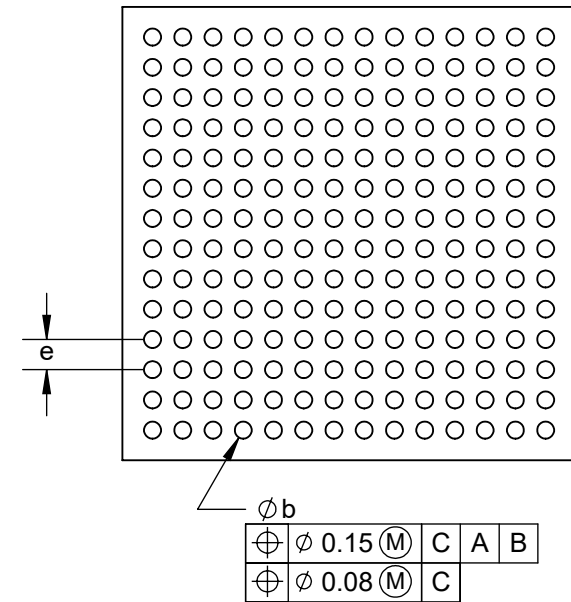

BOTTOM VIEW

1. Dimensions are in millimeters.
2. Interpret dimensions and tolerances per ASME Y14.5M-1994.
3. Dimension b is measured at the maximum solder ball diameter, parallel to datum plane C.
4. Datum C (seating plane) is defined by the spherical crowns of the solder balls.
5. Parallelism measurement shall exclude any effect of mark on top surface of package.

Description: Compatible BGA

Primary dimension units are millimeters, Secondary dimension units are [inches], Weight is in grams.

Tolerances: Hole diameters $\pm 0.03\text{mm}$ [$\pm 0.001"$], Pitches (from true position) $\pm 0.025\text{mm}$ [$\pm 0.001"$], substrate thickness tolerance $\pm 10\%$, all other tolerances $\pm 0.13\text{mm}$ [$\pm 0.005"$] unless stated otherwise. Materials and specifications are subject to change without notice.

DIM	Minimum	Nominal	Maximum
A			2.5
A1	0.2		0.34
b			0.50
D	12.00 BSC		
E	12.00 BSC		
e	0.80 BSC		
ARRAY	14 x 14		
PIN COUNT			144

 CBT-BGA-6002 Drawing Ironwood Electronics, Inc. Tele: (800) 404-0204 www.ironwoodelectronics.com	Material: N/A Finish: N/A Weight: 77.65	STATUS: Released ENG: E. Smolentseva FILE: CBT-BGA-6002 Dwg	SHEET: 3 OF 5 DRAWN BY: M. Raske DATE: 04/16/2015	REV. C SCALE: 5:1

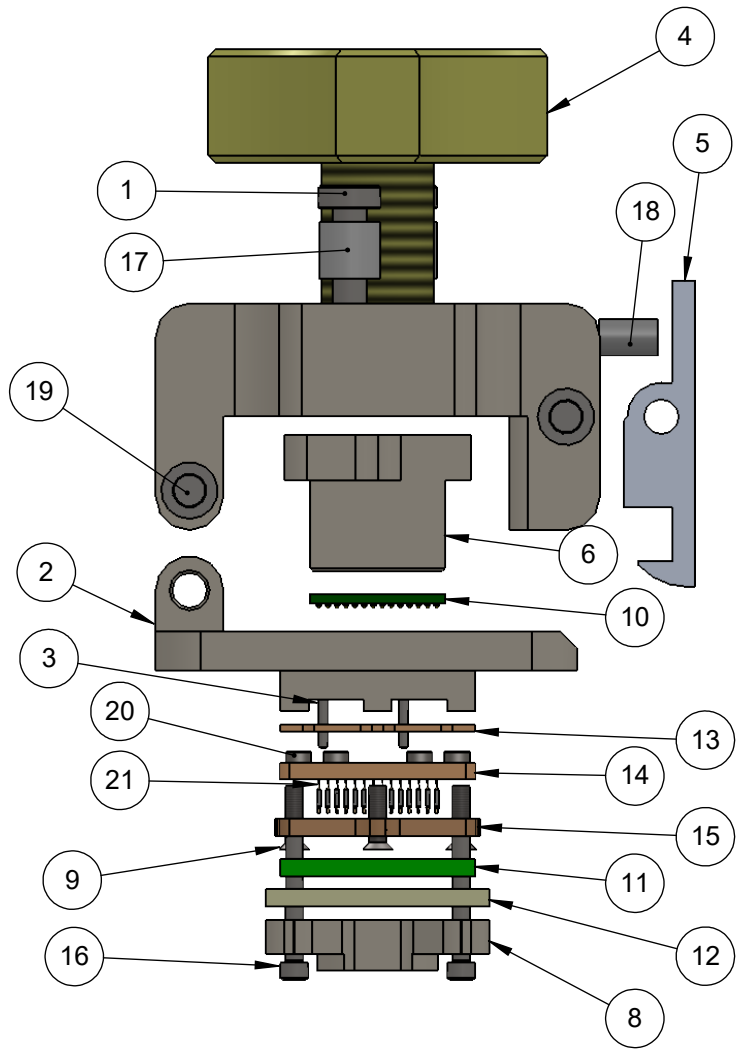

ITEM NO.	DESCRIPTION	Material
1	Screw, M3 x 12mm, Low Head Cap, SS	18-8 Stainless Steel
2	Socket Base	7075-T6 Aluminum Alloy
3	Dowel pin, 1/32" X 1/4", SS	Stainless Steel (18-8)
4	COMPRESSION SCREW, 17MM X M10	7075-T6 Aluminum Alloy
5	Latch 10-17mm clamshell	7075-T6 Aluminum Alloy
6	Compression Plate	7075-T6 Aluminum Alloy
7	Clam Shell	7075-T6 Aluminum Alloy
8	Backing Plate	7075-T6 Aluminum Alloy
9	#0-80, 90 deg., head pin guide screw, Peek material 5.5715mm overall Length	PEEK unfilled
10	BGA196 ,0.8mm Pitch	FR4
11	Target PCB BGA196	Custom Plastic
12	Insulation Plate	FR4 High temp
13	Floating Guide 12mm 0.8mm 14x14array	Semitron MDS 100
14	Middle Pogo Guide 12mm 0.8mm 14x14 arr	Semitron MDS 100
15	Bottom Guide 12mm 0.8mm 14x14 arr	Semitron MDS 100
16	#0-80 x 0.5, SH Cap Screw	Alloy Steel
17	Spring Clamshell lid assembly	Steel Music Wire
18	Precision Compression Spring, Zinc-Plated Music Wire, 1/2" Length, .12" OD, .016" Wire	Zinc Plated Music Wire
19	Hinge Pin and Snap Ring, 3mm OD, 25mm long, SS	Stainless Steel (ferritic)
20	Floating Guide Spring	Alloy Steel (SS)
21	SBT Pin, SBT-BGA 0.5mm-0.8mm	

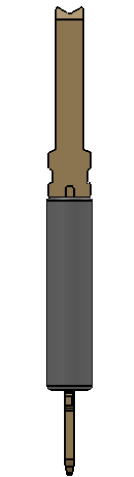

Pin Detail

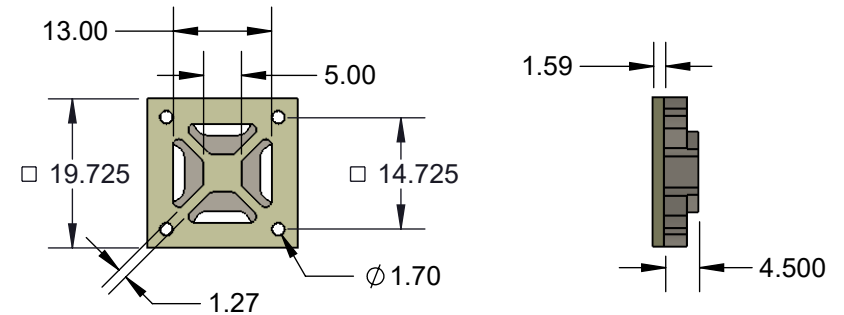

Insulation and Backing Plate

Description: Socket Assy, Insulation Plate

Primary dimension units are millimeters, Secondary dimension units are [inches], Weight is in grams.

Tolerances: Hole diameters $\pm 0.03\text{mm}$ [$\pm 0.001"$], Pitches (from true position) $\pm 0.025\text{mm}$ [$\pm 0.001"$], substrate thickness tolerance $\pm 10\%$, all other tolerances $\pm 0.13\text{mm}$ [$\pm 0.005"$] unless stated otherwise. Materials and specifications are subject to change without notice.

 CBT-BGA-6002 Drawing Ironwood Electronics, Inc. Tele: (800) 404-0204 www.ironwoodelectronics.com	Material: N/A Finish: N/A Weight: 77.65	STATUS: Released	SHEET: 4 OF 5	REV. C
		ENG: E. Smolentseva	DRAWN BY: M. Raske	SCALE: 3:2
		FILE: CBT-BGA-6002 Dwg	DATE: 04/16/2015	

Rev	Date	Initials	Description
B	4/16/15	RP/MR	Changed spring pin and guides to new design, dowel pin protrusion adjusted, if needed, metal screws replaced with plastic screws, if needed. Contact Ironwood for details.
C	9/20/16	MR	corrected description property per redline

Description: Sheet1

Primary dimension units are millimeters, Secondary dimension units are [inches], Weight is in grams.

Tolerances: Hole diameters $\pm 0.0254\text{mm}$ [$\pm 0.001"$], Pitches (from true position) $\pm 0.0762\text{mm}$ [$\pm 0.003"$], substrate thickness tolerance $\pm 10\%$, all other tolerances $\pm 0.127\text{mm}$ [$\pm 0.005"$] unless stated otherwise. Materials and specifications are subject to change without notice.

 CBT-BGA-6002 Drawing ©2015 Ironwood Electronics, Inc. Tele: (800) 404-0204 www.ironwoodelectronics.com	Material: Finish: Weight:	STATUS: Released	SHEET: 5 OF 5	REV. C
		ENG: E. Smolentseva	DRAWN BY: M. Raske	SCALE: 3:2
		FILE: CBT-BGA-6002 Dwg	DATE: 04/16/2015	