

# CBT-LGA DIRECT MOUNT, SOLDERLESS SOCKET FOR BURN-IN AND TEST APPLICATIONS

Can be used as a Test Handler Socket (see page 5 for details)

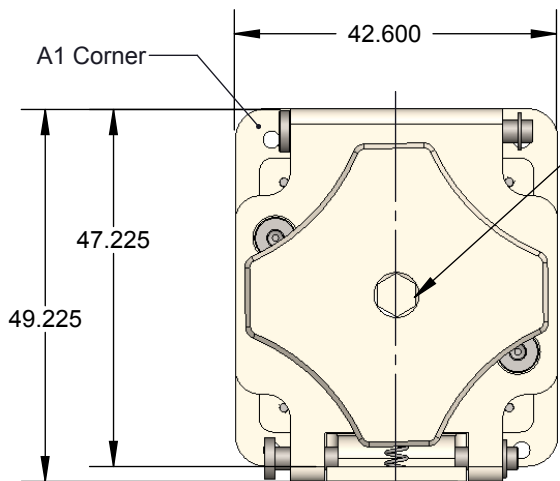

Recommended torque = 10-12 in-lbs

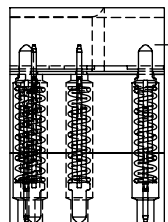

DETAIL A  
SCALE 8 : 1

## Features

- Wide temperature range (-55C to +180C).
- High current capability (up to 4A).
- Excellent signal integrity at high frequencies.
- Low and stable contact resistance for reliable production yield.
- Highly compliant to accommodate wide co-planarity variations.
- Automated probe manufacturing enables low cost and short lead time.

0.380 Stroke length (Uncompressed height measured from bottom of socket pocket)

TOP VIEW

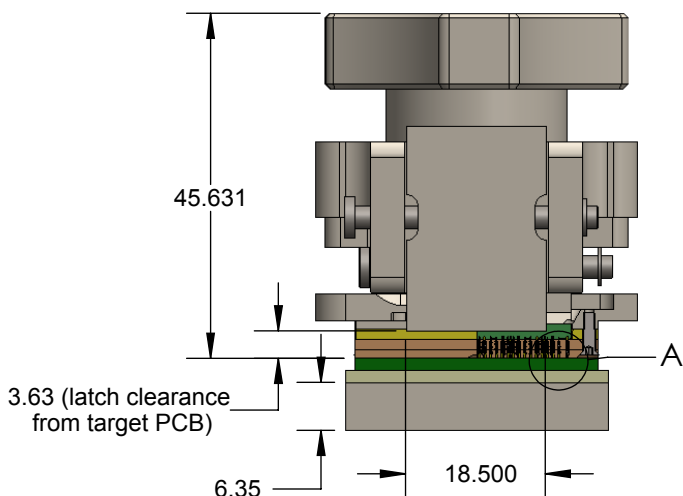

FRONT VIEW

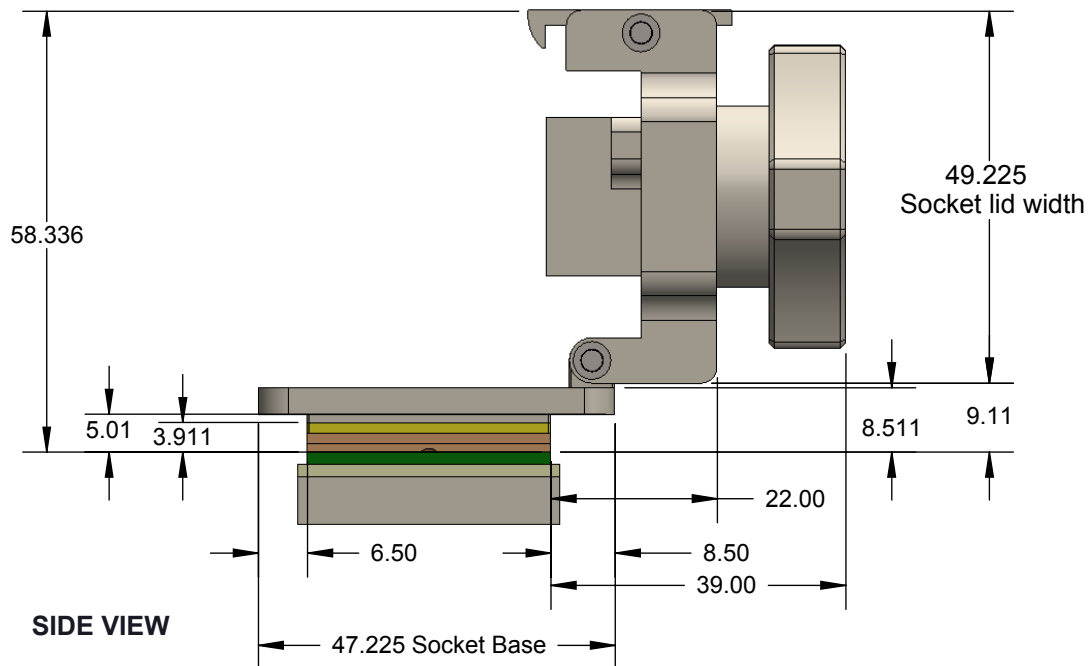

SIDE VIEW

## Description: CBT-LGA110 25x21mm 0.75mm pitch

Primary dimension units are millimeters, Secondary dimension units are [inches], Weight is in grams.

Tolerances: Hole diameters  $\pm 0.03\text{mm}$  [ $\pm 0.001"$ ], Pitches (from true position)  $\pm 0.025\text{mm}$  [ $\pm 0.001"$ ], substrate thickness tolerance  $\pm 10\%$ , all other tolerances  $\pm 0.13\text{mm}$  [ $\pm 0.005"$ ] unless stated otherwise. Materials and specifications are subject to change without notice.

 <b>CBT-LGA-5003 Drawing</b> Ironwood Electronics, Inc. Tele: (800) 404-0204 www.ironwoodelectronics.com	Material: N/A Finish: N/A Weight: 151.22	STATUS: Released ENG: S. Faiz FILE: CBT-LGA-5003 Dwg	SHEET: 1 OF 5 DRAWN BY: M. Raske DATE: 9/23/2013	REV. B SCALE: 1:1

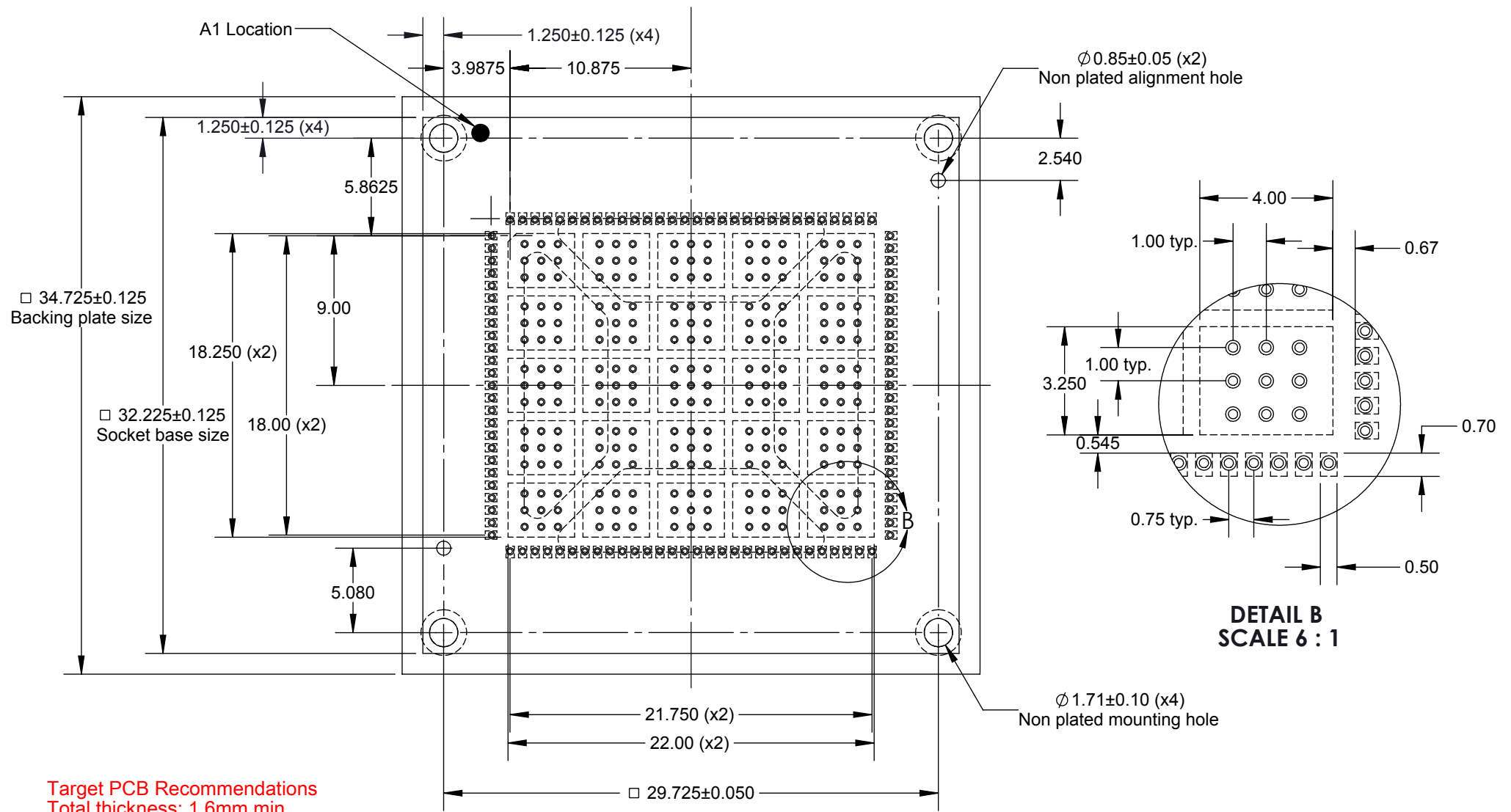

Target PCB Recommendations  
 Total thickness: 1.6mm min.  
 Plating: Gold or Solder finish  
 PCB Pad height: same or higher than solder mask

**Description: Recommended PCB layout**

Primary dimension units are millimeters, Secondary dimension units are [inches], Weight is in grams.  
 Tolerances: Hole diameters ±0.03mm [±0.001"], Pitches (from true position) ±0.025mm [±0.001"], substrate thickness tolerance ±10%, all other tolerances ±0.13mm [±0.005"] unless stated otherwise. Materials and specifications are subject to change without notice.

 <b>CBT-LGA-5003 Drawing</b> Ironwood Electronics, Inc. Tele: (800) 404-0204 www.ironwoodelectronics.com	Material: N/A Finish: N/A Weight: 151.22	STATUS: Released ENG: S. Faiz FILE: CBT-LGA-5003 Dwg	SHEET: 2 OF 5 DRAWN BY: M. Raske DATE: 9/23/2013	REV. B SCALE: 3:1

Ironwood package code: LGA110A

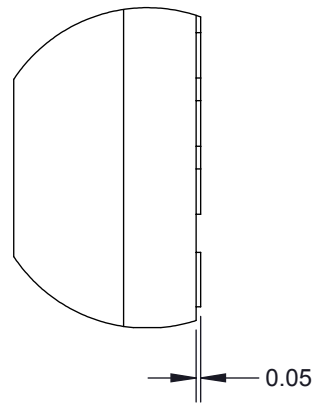
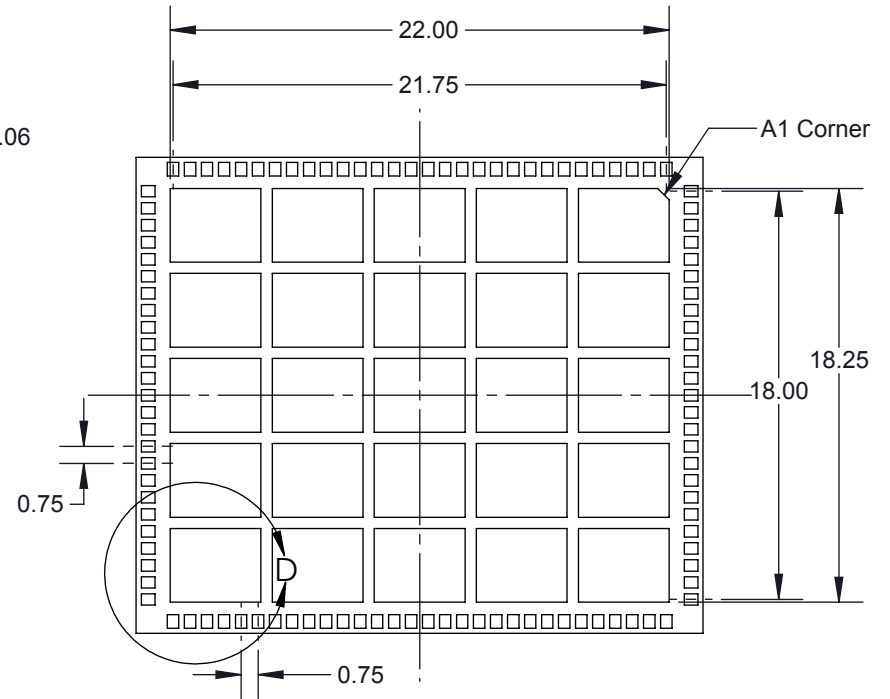
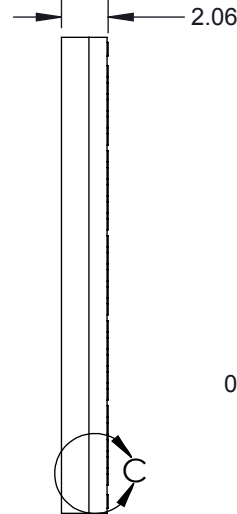
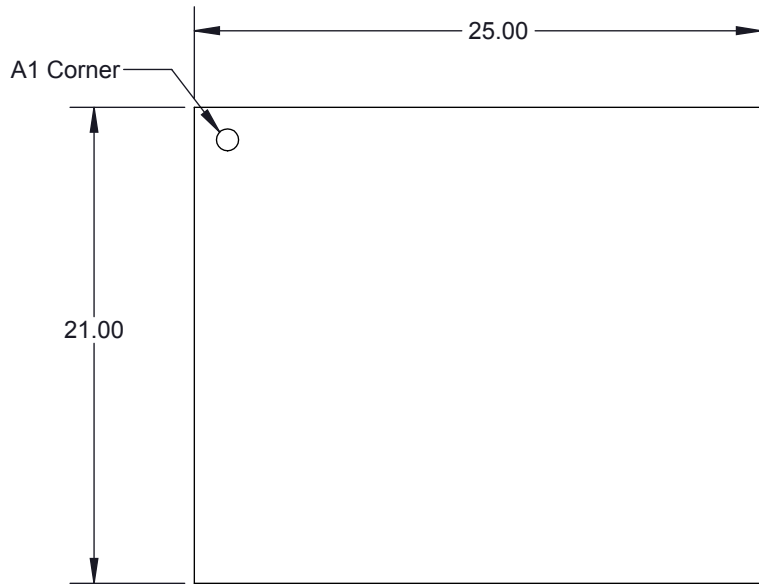

**DETAIL C**  
SCALE 12 : 1

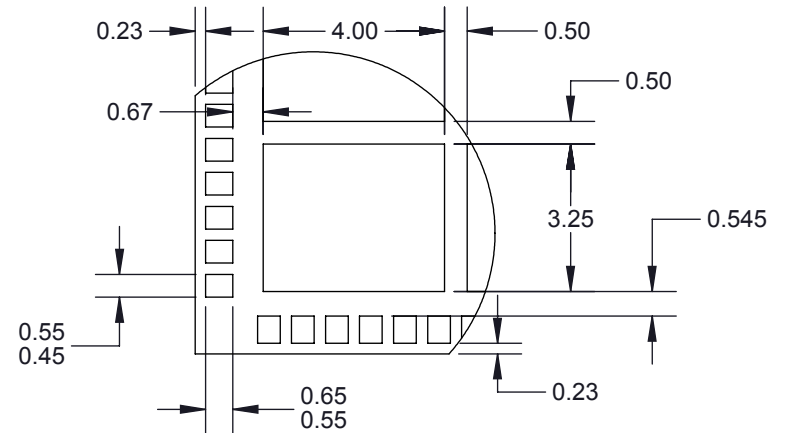

**DETAIL D**  
SCALE 6 : 1

**Description: LGA**

Primary dimension units are millimeters, Secondary dimension units are [inches], Weight is in grams.

Tolerances: Hole diameters  $\pm 0.03\text{mm}$  [ $\pm 0.001"$ ], Pitches (from true position)  $\pm 0.025\text{mm}$  [ $\pm 0.001"$ ], substrate thickness tolerance  $\pm 10\%$ , all other tolerances  $\pm 0.13\text{mm}$  [ $\pm 0.005"$ ] unless stated otherwise. Materials and specifications are subject to change without notice.

 <p><b>CBT-LGA-5003 Drawing</b> Ironwood Electronics, Inc. Tele: (800) 404-0204 www.ironwoodelectronics.com</p>	<p>Material: N/A Finish: N/A Weight: 151.22</p>	<p>STATUS: Released ENG: S. Faiz FILE: CBT-LGA-5003 Dwg</p>	<p>SHEET: 3 OF 5 DRAWN BY: M. Raske DATE: 9/23/2013</p>	<p>REV. B SCALE: 3:1</p>

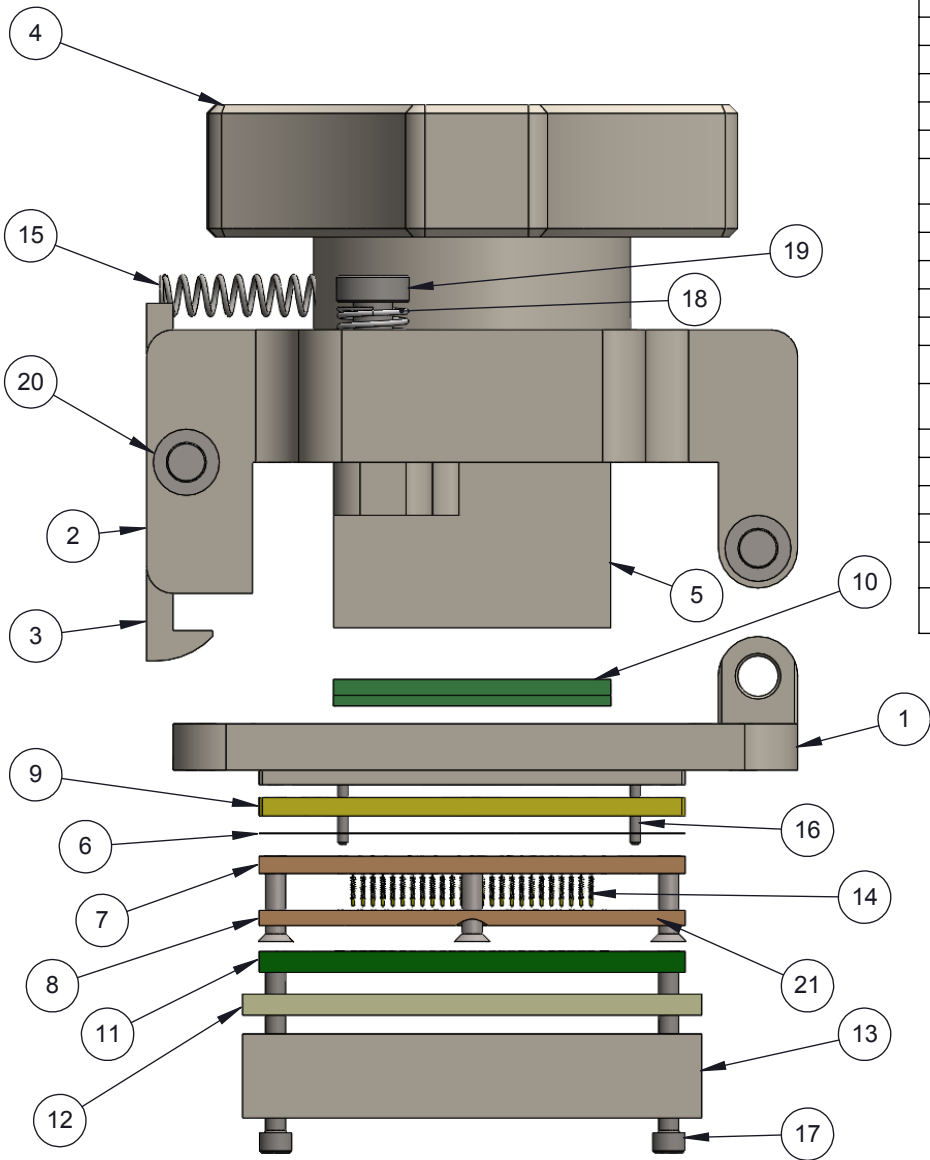

ITEM NO.	DESCRIPTION	Material
1	CBT socket base 25mm	7075-T6 Aluminum Alloy
2	Socket Lid	7075-T6 Aluminum Alloy
3	Latch	7075-T6 Aluminum Alloy
4	Compression Screw	7075-T6 Aluminum Alloy
5	Compression plate	7075-T6 Aluminum Alloy
6	Pin Orientation Guide - LGA110 0.75mm pitch 25x21mm	Kapton Polyimide
7	SBT Top Spring Pin Guide - LGA110 0.75mm 25x12mm	Semitron MDS 100
8	SBT Bottom Spring Pin Guide - LGA110 0.75mm pitch 25x21mm	Semitron MDS 100
9	IC Guide 25x21mm	Torlon 4203
10	IC, LGA110 0.75mm pitch 25x21mm	High Temp FR4
11	PCB LGA110 0.75mm 25x12mm	High Temp FR4
12	Insulation Plate 27mm IC	FR4
13	Backing Plate 27x27mm	7075-T6 Aluminum Alloy
14	SBT-LGA/QFN Pogo Pin, 0.5mm-0.8mm	Contact Mtrl: BeCu, Au Plated over Ni
15	Precision Compression Spring, Zinc-Plated Music Wire, 1/2" Length, .12" OD, .016" Wire	Zinc Plated Music Wire
16	Dowel pin, 1/32" X 1/4", SS	Stainless Steel (18-8)
17	#0-80 x 0.5, SH Cap Screw	Alloy Steel
18	Spring Clamshell lid assembly	Steel Music Wire
19	Screw, M3 x 12mm, Low Head Cap, SS	18-8 Stainless Steel
20	Hinge Pin and Snap Ring, 3mm OD, 30mm long, 1045 Stl, Blk Oxide	AISI 1045 Steel, cold drawn
21	#0-80, 90 deg., head pin guide screw, Peek material 5.5715mm overall Length	PEEK unfilled

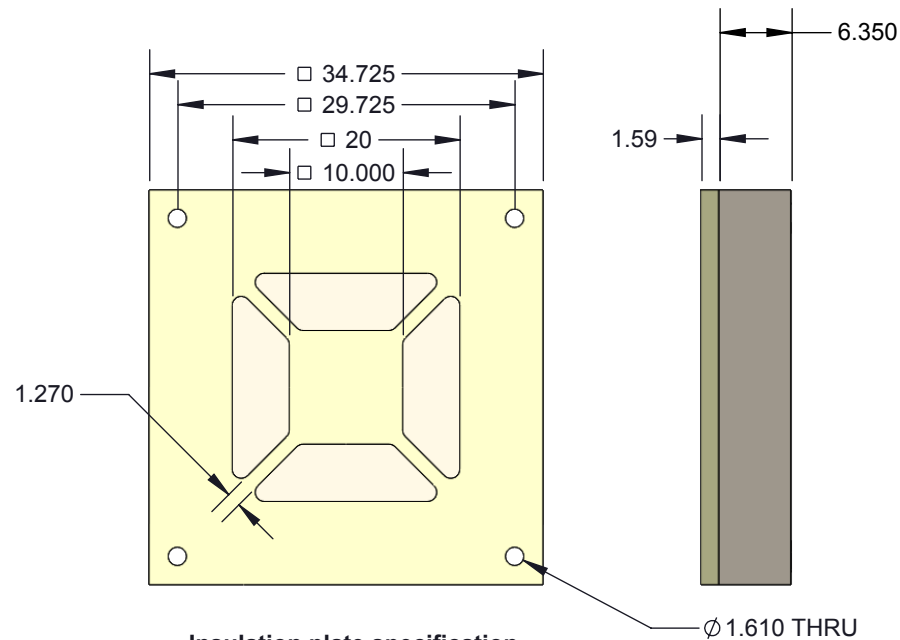

**Insulation plate specification**

### Description: Socket Assy

Primary dimension units are millimeters, Secondary dimension units are [inches], Weight is in grams.

**Tolerances:** Hole diameters  $\pm 0.03\text{mm}$  [ $\pm 0.001"$ ], Pitches (from true position)  $\pm 0.025\text{mm}$  [ $\pm 0.001"$ ], substrate thickness tolerance  $\pm 10\%$ , all other tolerances  $\pm 0.13\text{mm}$  [ $\pm 0.005"$ ] unless stated otherwise. Materials and specifications are subject to change without notice.

 <b>CBT-LGA-5003 Drawing</b> Ironwood Electronics, Inc. Tele: (800) 404-0204 www.ironwoodelectronics.com	Material: N/A Finish: N/A Weight: 151.22	STATUS: Released ENG: S. Faiz FILE: CBT-LGA-5003 Dwg	SHEET: 4 OF 5 DRAWN BY: M. Raske DATE: 9/23/2013	REV. B SCALE: 1.75:1
-----------------------------------------------------------------------------------------------------------------------------------------------------------------------------------------------------	------------------------------------------------	------------------------------------------------------------	--------------------------------------------------------	-------------------------

# Lid removed for Handler applications

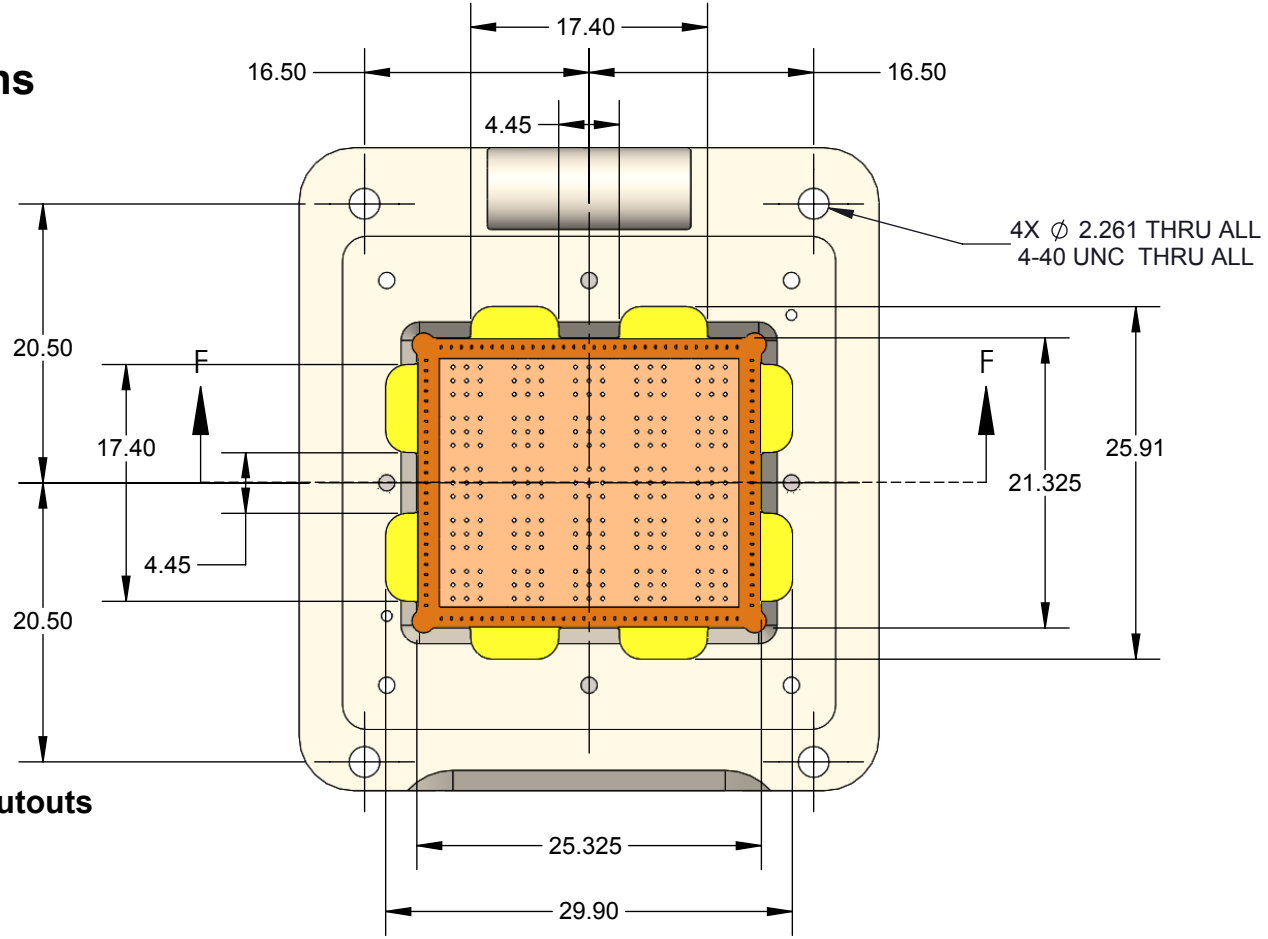

**Socket base with cutouts (TOP VIEW)**

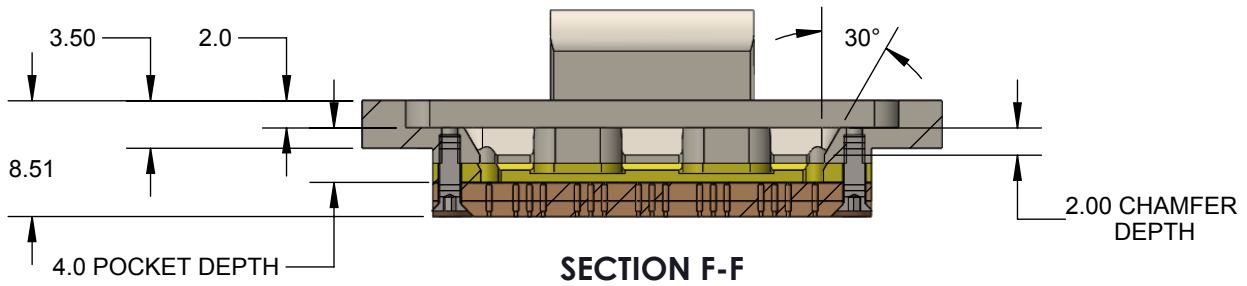

**SECTION F-F**

## Description: socket base

Primary dimension units are millimeters, Secondary dimension units are [inches], Weight is in grams.  
 Tolerances: Hole diameters  $\pm 0.03\text{mm}$  [ $\pm 0.001"$ ], Pitches (from true position)  $\pm 0.025\text{mm}$  [ $\pm 0.001"$ ], substrate thickness tolerance  $\pm 10\%$ , all other tolerances  $\pm 0.13\text{mm}$  [ $\pm 0.005"$ ] unless stated otherwise. Materials and specifications are subject to change without notice.

Rev	Date	Initials	Description
A	09/23/13	MR	Original
B	08/14/14	DH	Changed IC Guide material to Torlon

 <b>CBT-LGA-5003 Drawing</b> Ironwood Electronics, Inc. Tele: (800) 404-0204 www.ironwoodelectronics.com	Material: N/A Finish: N/A Weight: 151.22	STATUS: Released ENG: S. Faiz FILE: CBT-LGA-5003 Dwg	SHEET: 5 OF 5 DRAWN BY: M. Raske DATE: 9/23/2013	REV. B SCALE: 1.8:1
-----------------------------------------------------------------------------------------------------------------------------------------------------------------------------------------------------	------------------------------------------------	------------------------------------------------------------	--------------------------------------------------------	------------------------