

REV	ECO	BY	DESCRIPTION	APV	DATE
A	XXXX	JEB	INITIAL DESIGN	DJP	8/4/21

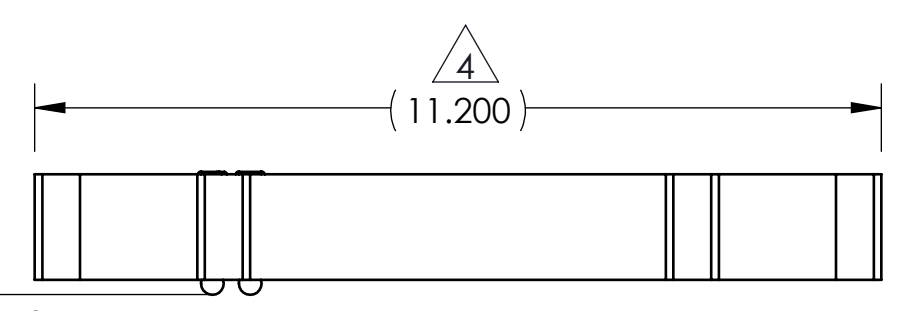

TO BOTTOM ON SOCKETS WITH SOLDER BALLS

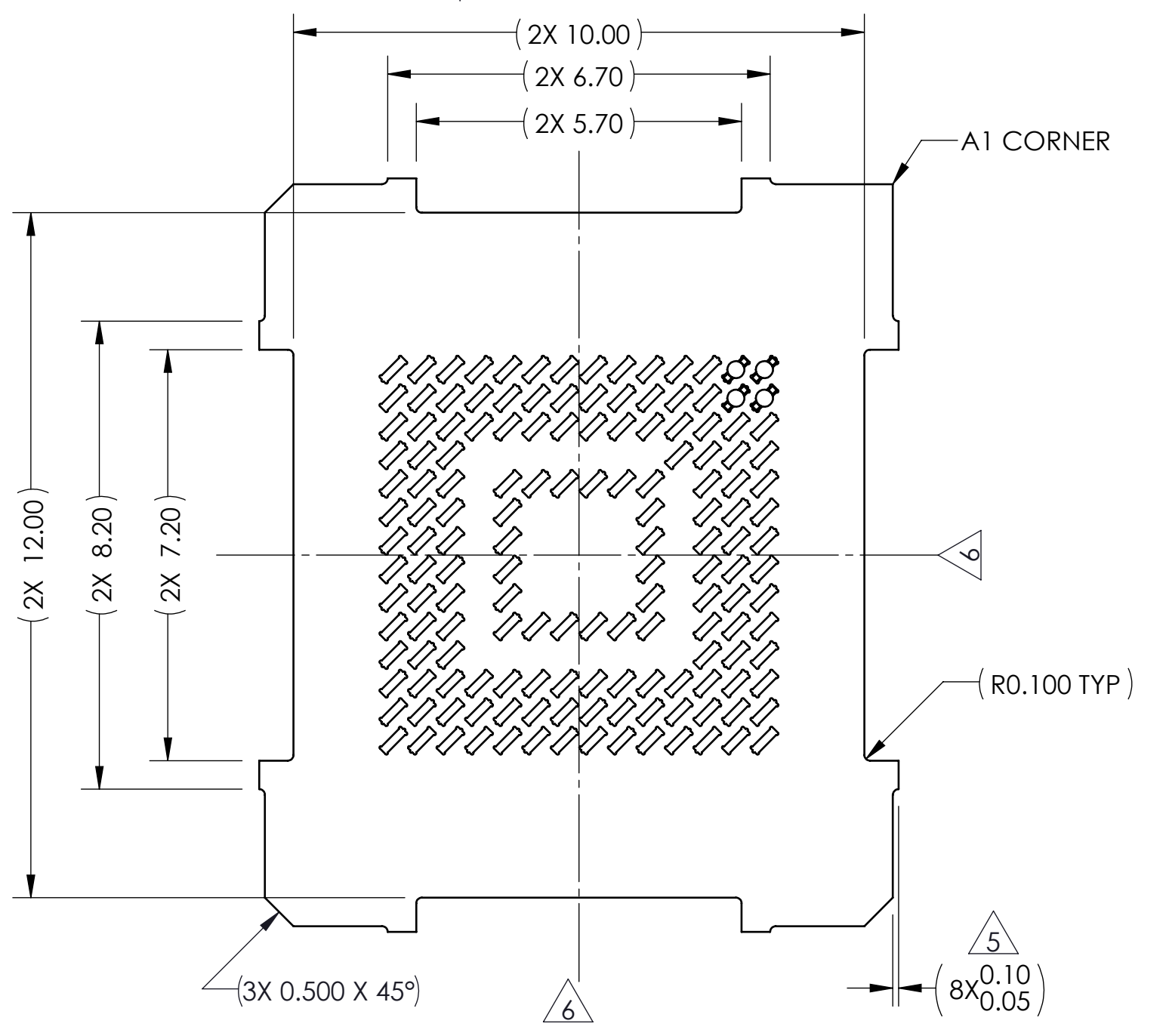
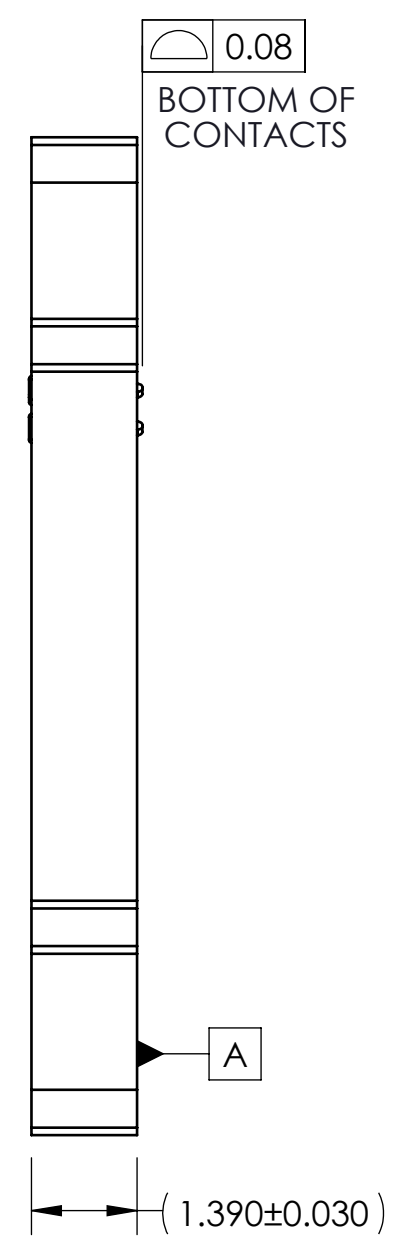
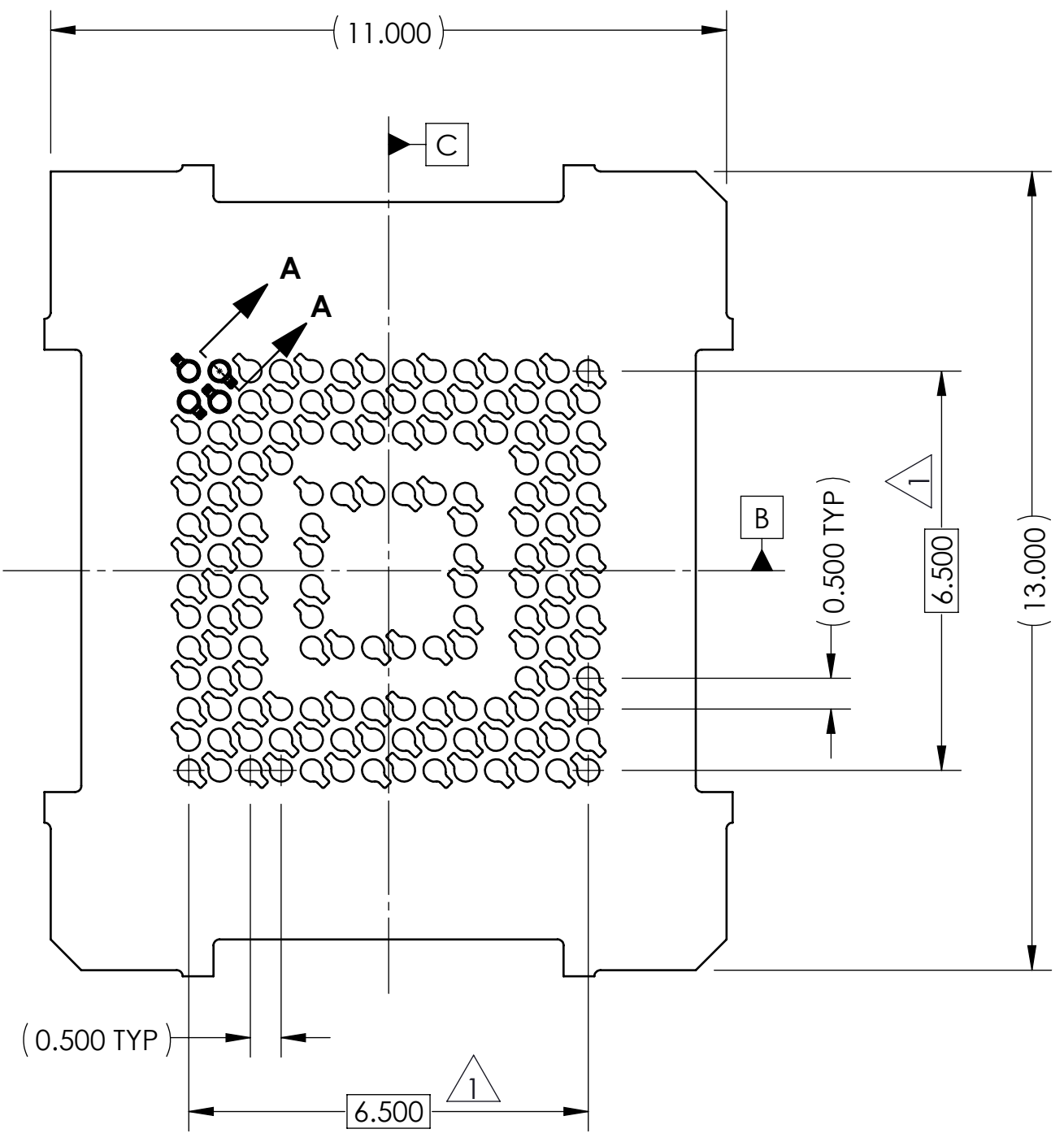
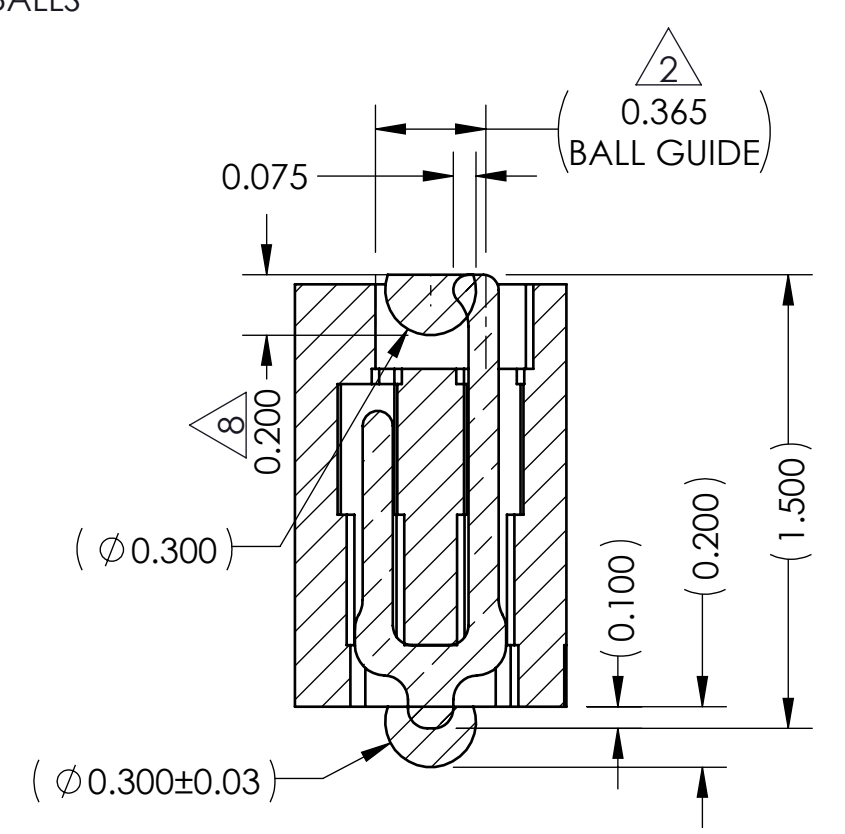

SECTION A-A
SCALE 40:1

Notes:

- 1 LOCATES CENTER OF CONTACT SLOTS.
- 2 DATUM [B] AND [C] DETERMINED BY Ø0.365 OPENING IN CORNER SLOTS.
- 3 UNLESS OTHERWISE NOTED, ALL FEATURES LOCATED $\oplus 0.10$ [A] [B] [C].
- 4 INCLUDES TOOLING PROTRUSIONS.
- 5 TOOLING MARKS PERMITTED. MAXIMUM 0.10 PROTRUSION SHOWN.
- 6 CENTERLINE OF SOCKET.
- 7 CONTACT NUMBER: 104468-0015.
- 8 MINIMUM SOLDER BALL EXPOSURE IS: 1/2 (Ø OF SOLDER BALL) + 0.05mm .
- 9 HOUSING NUMBER: 107247-0119
- 10 SEE CUSTOMER'S P.O.D. FOR ANY MISSING FORM TOLERANCE AND/OR DIMENSIONS.
- 11 SOCKET SHOWN FOR DEVICES THAT ARE WITHIN SPECIFIED SPECIFICATIONS.

PART NUMBER	DESCRIPTION
GR1135-0001	SCKT, 153G40 11.0X13.0-0.50, EUT (EUTECTIC SOLDER BALL)
GR1135-0002	SCKT, 153G40 11.0X13.0-0.50, SAC305 (SAC305 SOLDER BALL)
GR1135-0003	SCKT, 153G40 11.0X13.0-0.50 W/O (WITHOUT SOLDER BALL)
103864-0041	PRESS DEV, 11.0X13.0 (SOLD SEPARATELY)
104553-0318	STENCIL, FLEX 153BGA 10.0X10.0-0.30 (SOLD SEPARATELY)
108639-0180	ALIGN, FRAME, 11.0X13.0 (SOLD SEPARATELY)
105900-0004	EXTRACTION TOOL, 4 X 53 (SOLD SEPARATELY)

UNLESS OTHERWISE SPECIFIED - DIMENSIONS ARE IN MILLIMETERS - DIMS APPLY AFTER PLATING
TOLERANCES UNLESS OTHERWISE NOTED:
ANGLES ±1° DECIMALS X.X ±0.25
X.XX ±0.10 X.XXX ±0.050

THE INFORMATION CONTAINED IN THIS DRAWING IS THE SOLE PROPERTY OF IRONWOOD ELECTRONICS, INC. ANY REPRODUCTION IN PART OR WHOLE WITHOUT THE WRITTEN PERMISSION OF IRONWOOD ELECTRONICS, INC. IS PROHIBITED.

CAD GENERATED DRAWING
DO NOT MANUALLY UPDATE

IRONWOOD ELECTRONICS, INC
1335 EAGANDALE CT.
EAGAN, MN 55121. 952-229-8200

SCKT, 153G40 11.0X13.0-0.50

LEGEND:
 (X) NOTE CALLOUT
 (A) REVISION CHANGE
 (X) ITEM NUMBER

DRAWN: JEB DATE: 8/4/21
 APPVD: DJP DATE: 8/4/21

THIRD ANGLE PROJECTION

SCALE: C CAD FORMAT: SOLIDWORKS DRAWING NO.: GR1135-XXXX REV: A
 SHEET: 1 of 1

SEE B.O.M.