

REV	ECO	BY	DESCRIPTION	APV	DATE
A	31599	RS	Initial Release	NSJ	02/10/15

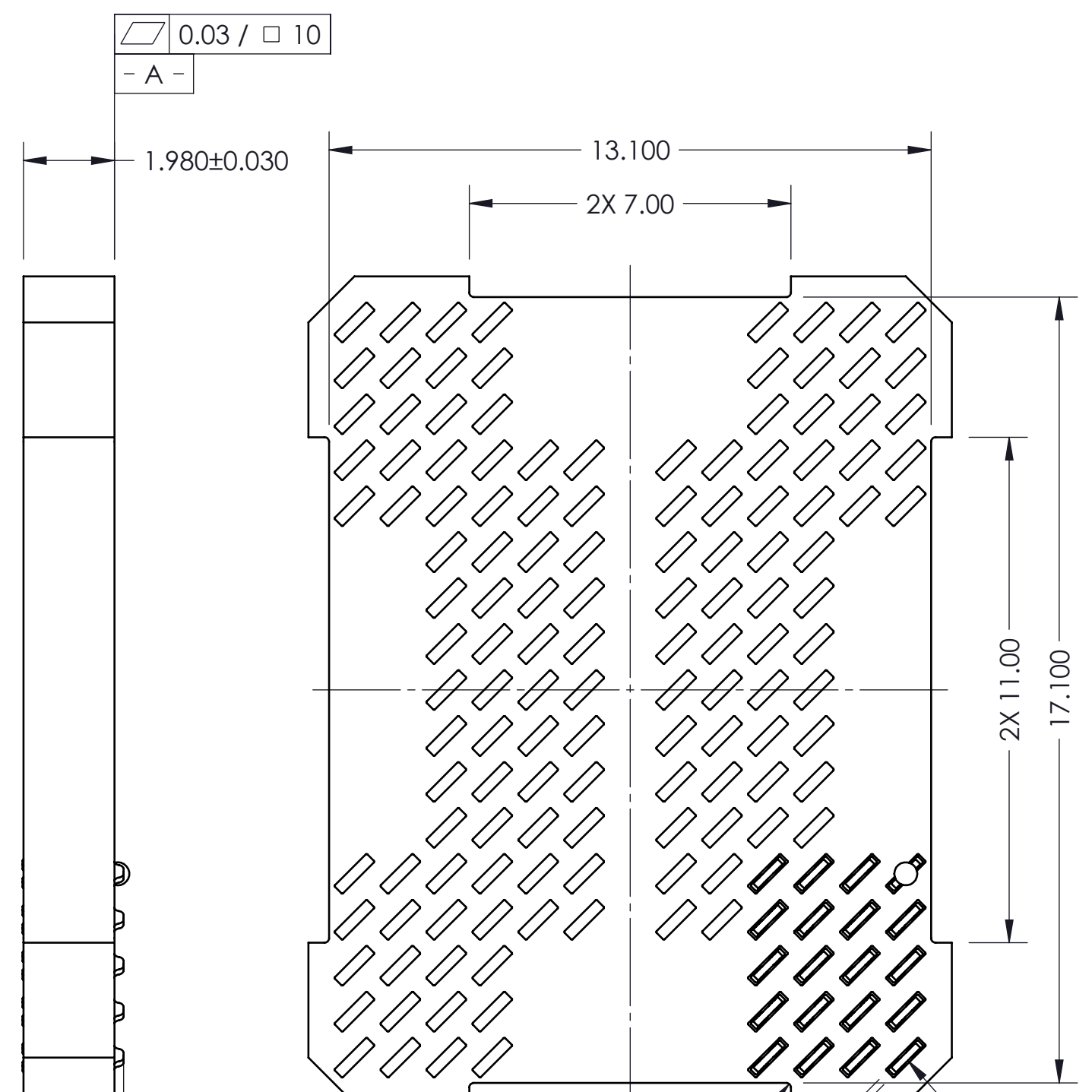

- Notes:
1. Dimension locates center of contact/slot.
 2. Footprint part number is 104311-0323.
 3. Press size is 14.00 X 18.00.
 4. Datums - B - and - C - are determined by $\varnothing 6.00$ opening in corner losts.
 5. Unless otherwise specified, all features located $\oplus 0.10$ A B C

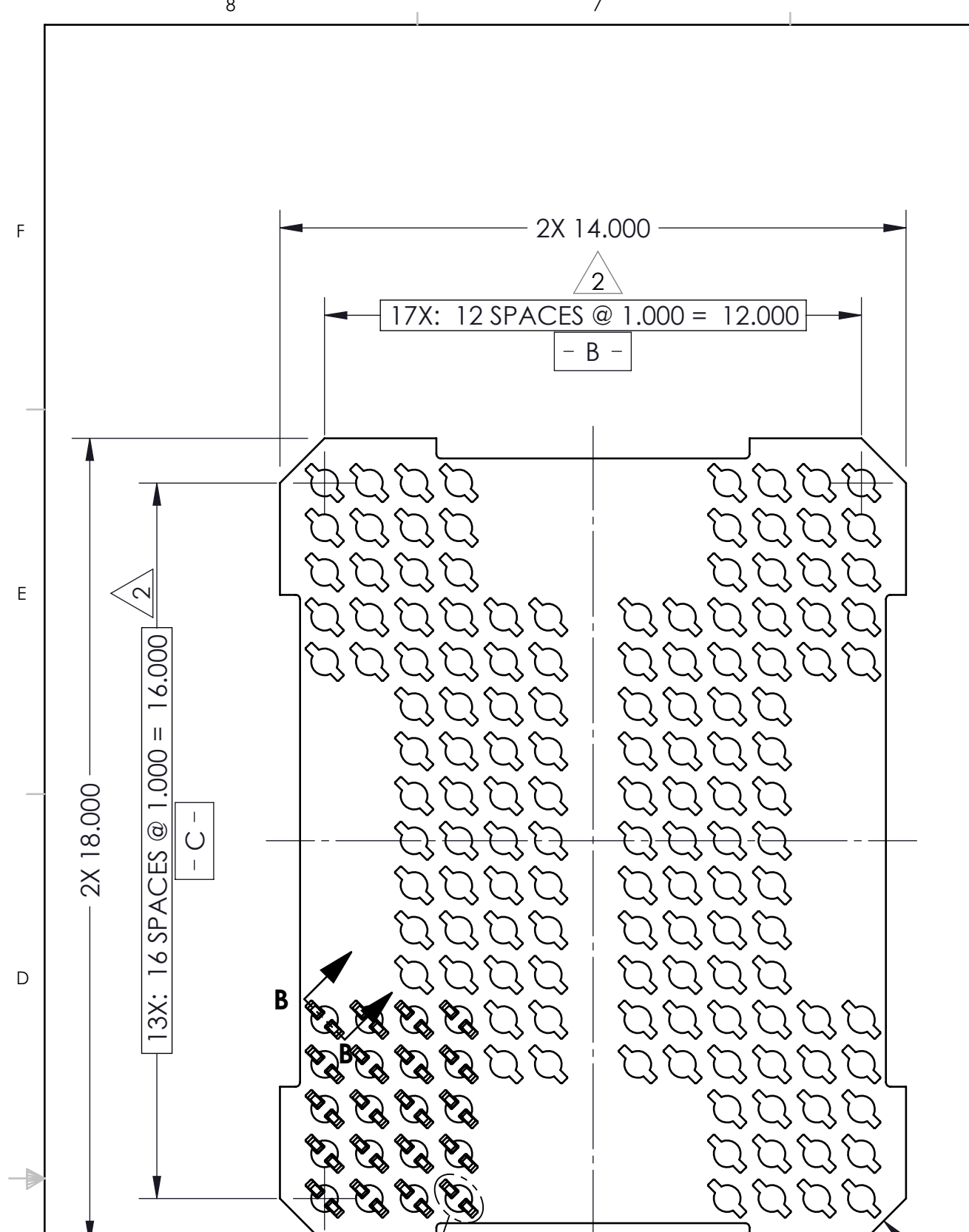
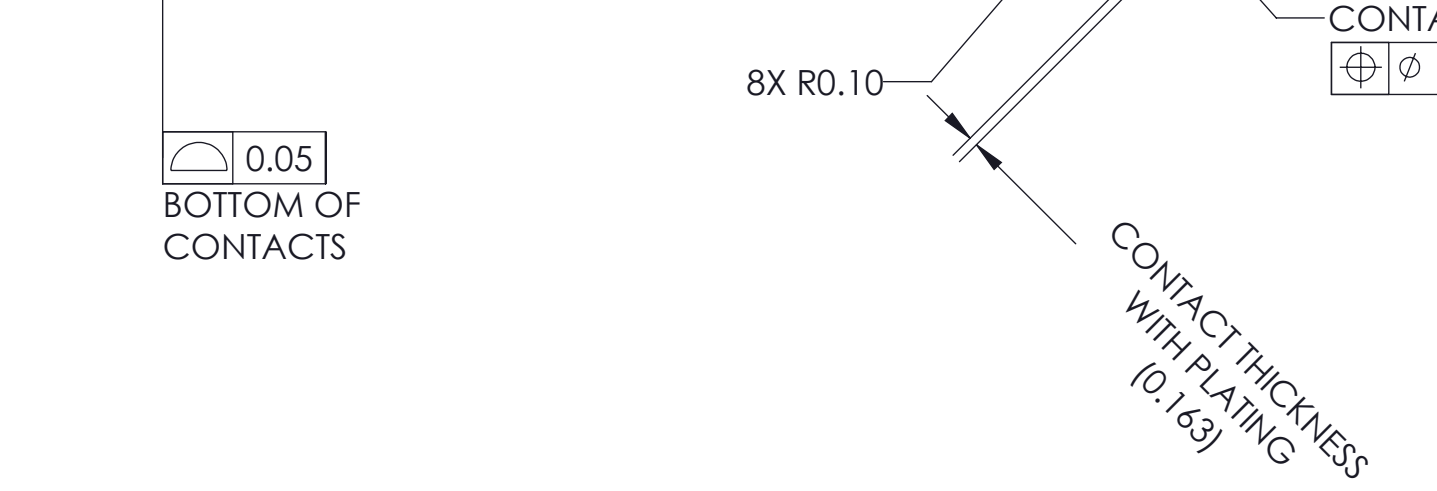

PARTS LIST	
PART NUMBER	DESCRIPTION
104671-0036	CS,152GRY14X18-1.00
103864-0116	PRESS, DEV INS, 14 X 18 (SOLD SEPARATELY)
104553-0248	STEN FLEX, 151GRY14X18-1.00 (SOLD SEPARATELY)

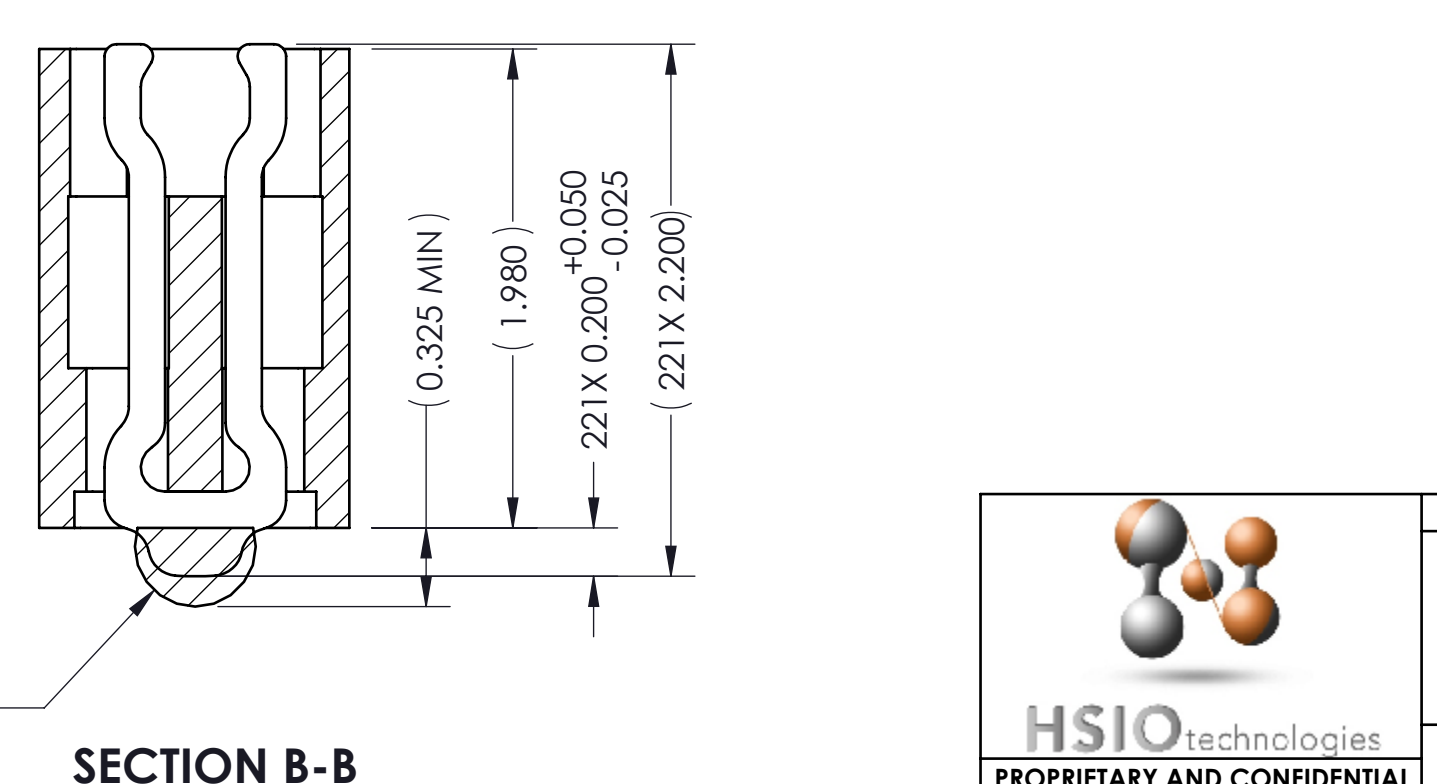
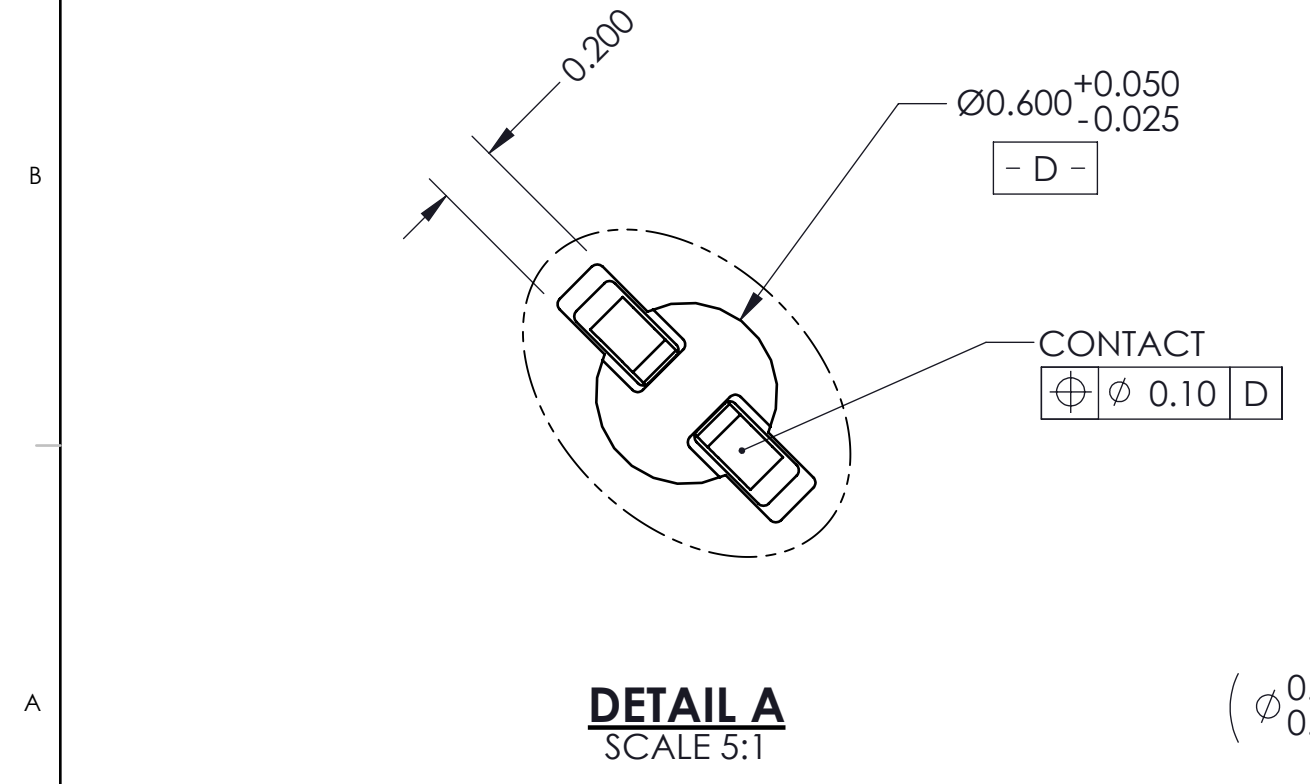

HSIO technologies
PROPRIETARY AND CONFIDENTIAL

THE INFORMATION CONTAINED IN THIS DRAWING IS THE SOLE PROPERTY OF HSIO TECHNOLOGIES, LLC. ANY REPRODUCTION IN PART OR AS A WHOLE WITHOUT THE WRITTEN PERMISSION OF HSIO TECHNOLOGIES, LLC IS PROHIBITED.

UNLESS OTHERWISE SPECIFIED:
DIMENSIONS ARE IN MILLIMETERS
TOLERANCES:
ANGULAR: ± 1°
X.X ± 0.25
X.XX ± 0.10
X.XXX ± 0.050

INTERPRET GEOMETRIC TOLERANCING PER:
MATERIAL: SEE BOM
FINISH:
DO NOT SCALE DRAWING

NAME	DATE
DRAWN RS	02/10/15
CHECKED RS	02/10/15

LEGEND:
△ NOTE CALLOUT
◻ REVISION CHANGE
○ ITEM NUMBER

HSIO TECHNOLOGIES, LLC.
13300 67th AVENUE NORTH
MAPLE GROVE, MINNESOTA 55311
763-447-6260

TITLE:
SCKT, 152GRY14X18-1.00,
SAC305

DWG. NO.	REV
104670-0041	A

SCALE: 5:1 | SIZE: C | SHEET 1 OF 2

Device Specification					
Lead Count	N	152	Package Size	D	14.00
Columns	ND	13	Ball Spacing	E	18.00
Rows	NE	17		D1	12.00
Pitch	e	1.000	Encapsulant/ Top Size	E1	16.00
Ball Size	b	0.50±0.05		D2	N/A
Total Thickness	A	N/A	Pattern Style	E2	N/A
Ball Height	A1	0.30 min	Perimeter Rows	Irregular	
Substrate Thickness	A2	N/A	Center Array	N/A	
Top Thickness	A3				
Form Tolerances					
Edge	aaa	0.20	Bottom	ddd	0.15
Substrate	bbb	0.20	Position	eee	0.20
top	ccc	0.20	Position	fff	0.08

All dimensions are in millimeters.
*See footprint specification for pattern details.

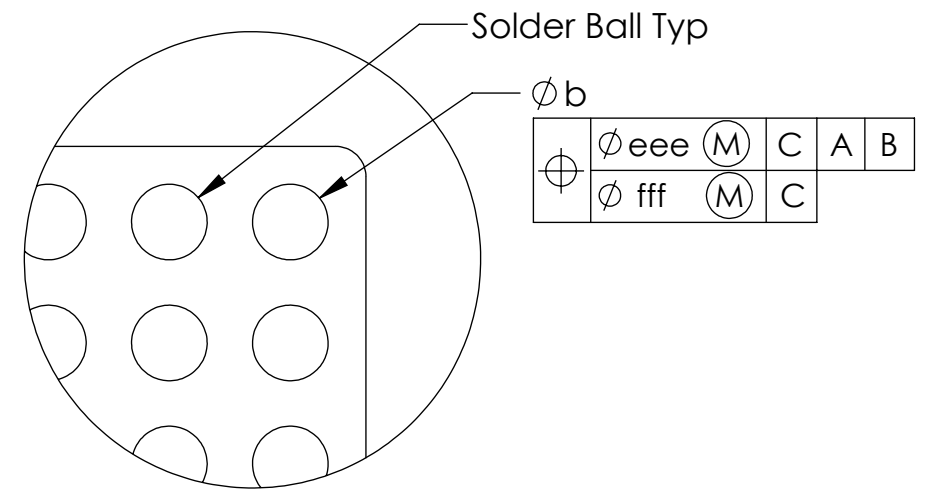
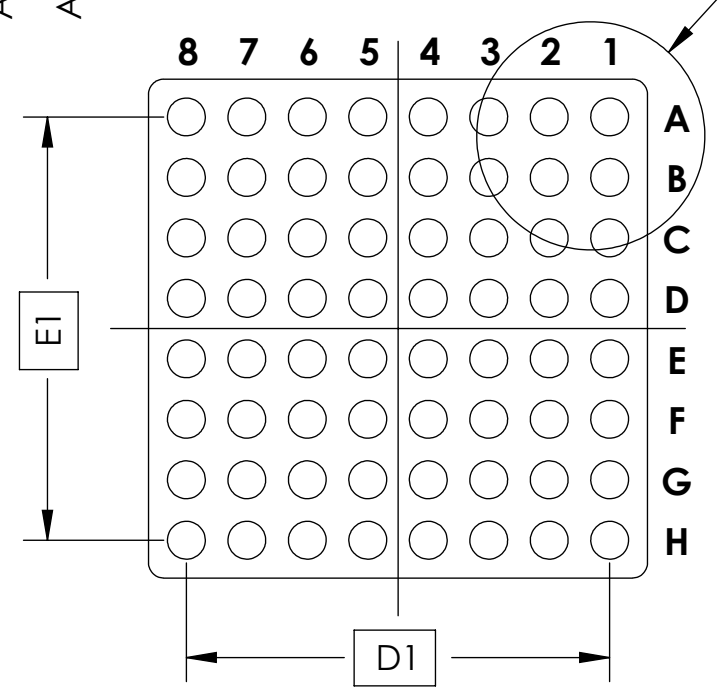
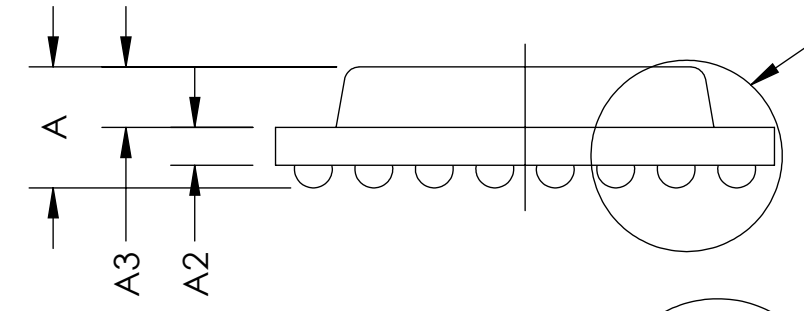
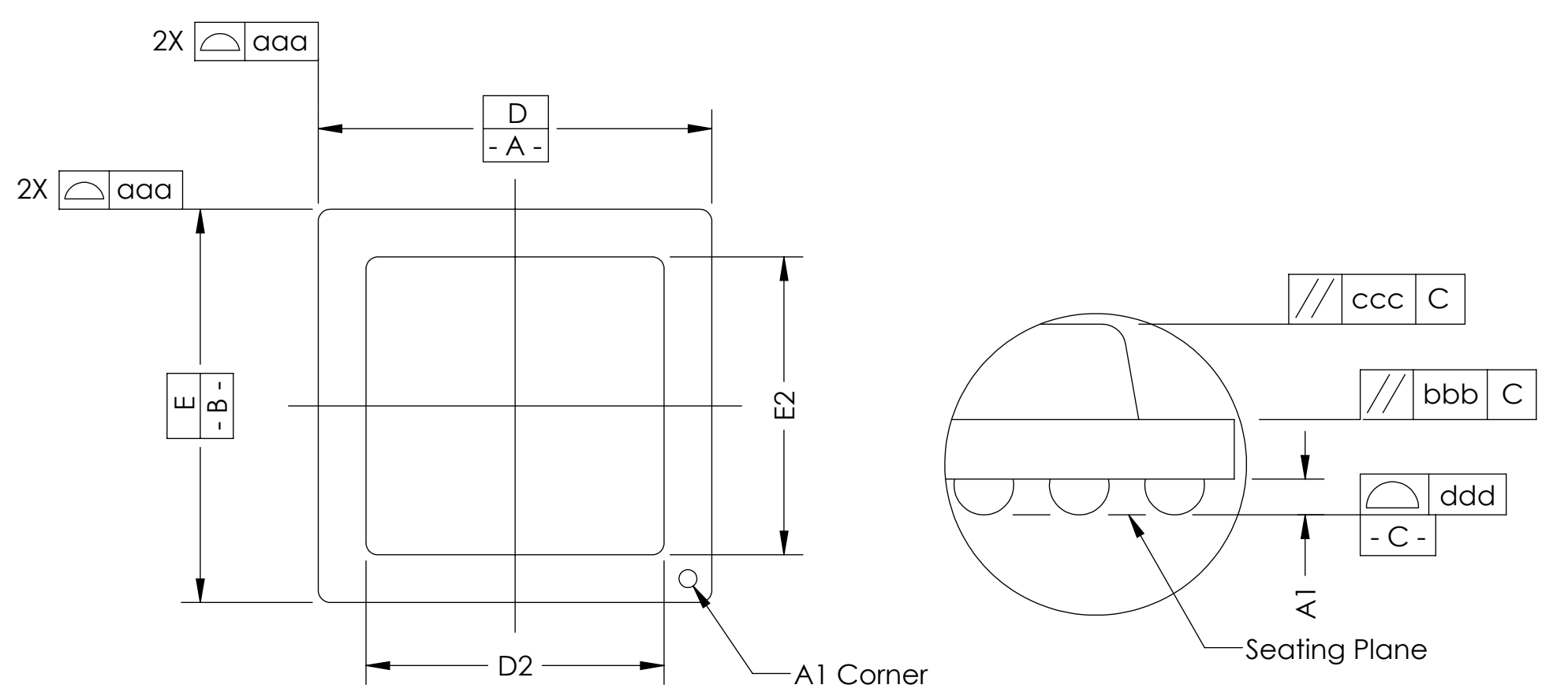
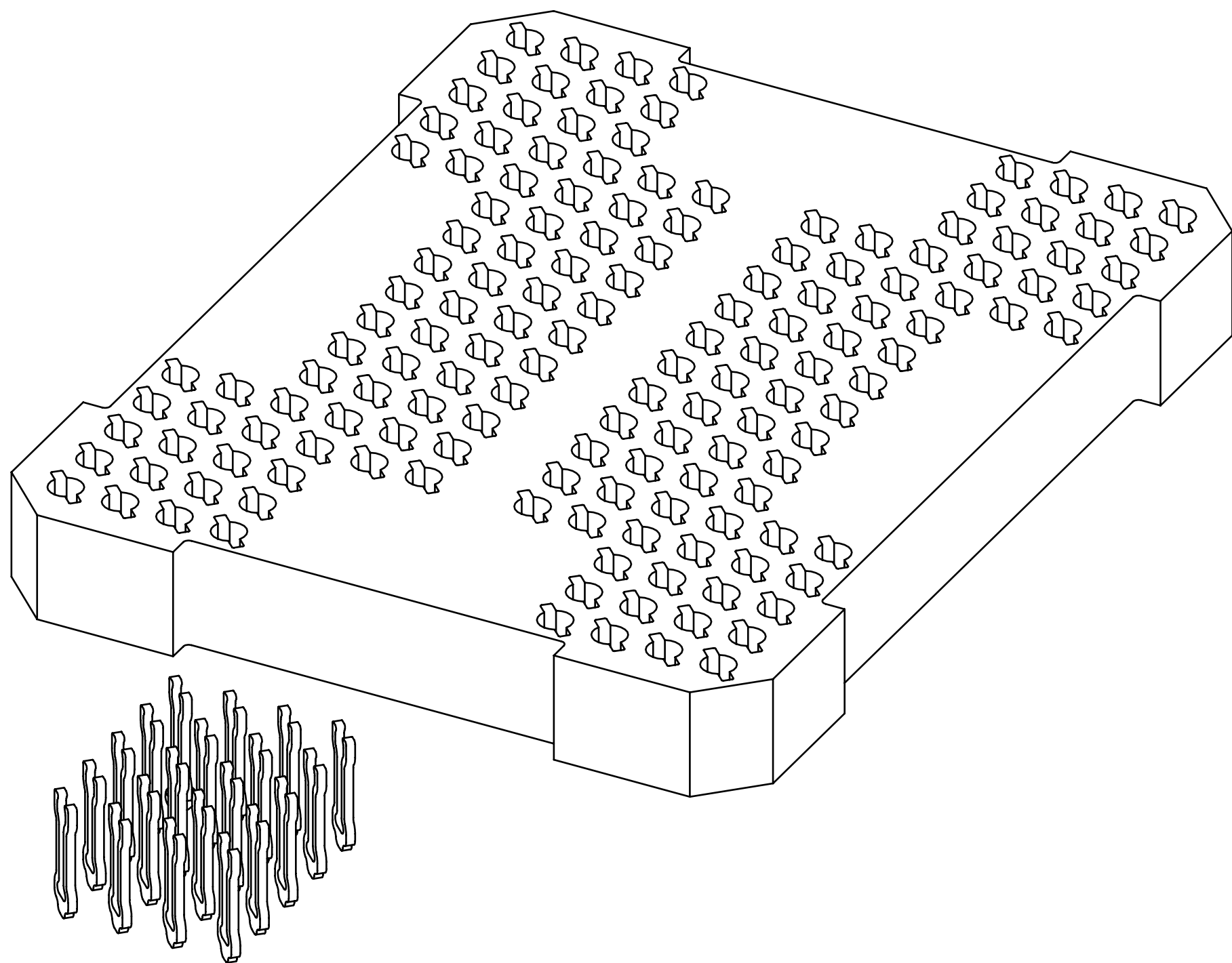

Generic Representation with Full Grid Array

PROPRIETARY AND CONFIDENTIAL

THE INFORMATION CONTAINED IN THIS DRAWING IS THE SOLE PROPERTY OF HSIO TECHNOLOGIES, LLC. ANY REPRODUCTION IN PART OR AS A WHOLE WITHOUT THE WRITTEN PERMISSION OF HSIO TECHNOLOGIES, LLC IS PROHIBITED.

UNLESS OTHERWISE SPECIFIED: DIMENSIONS ARE IN MILLIMETERS TOLERANCES: ANGULAR: ± 1° X.X ±0.25 X.XX ±0.10 X.XXX ±0.050	DRAWN	RS	DATE	02/10/15	HSIO TECHNOLOGIES, LLC. 13300 67th AVENUE NORTH MAPLE GROVE, MINNESOTA 55311 763-447-6260
	CHECKED	NSJ	DATE	02/10/15	

LEGEND:
 △ NOTE CALLOUT
 ◻ REVISION CHANGE
 ○ ITEM NUMBER

TITLE: SCKT, 152GRY14X18-1.00, SAC305	
DWG. NO. 104670-0041	REV A
SCALE: 5:1	SIZE: C SHEET 2 OF 2