

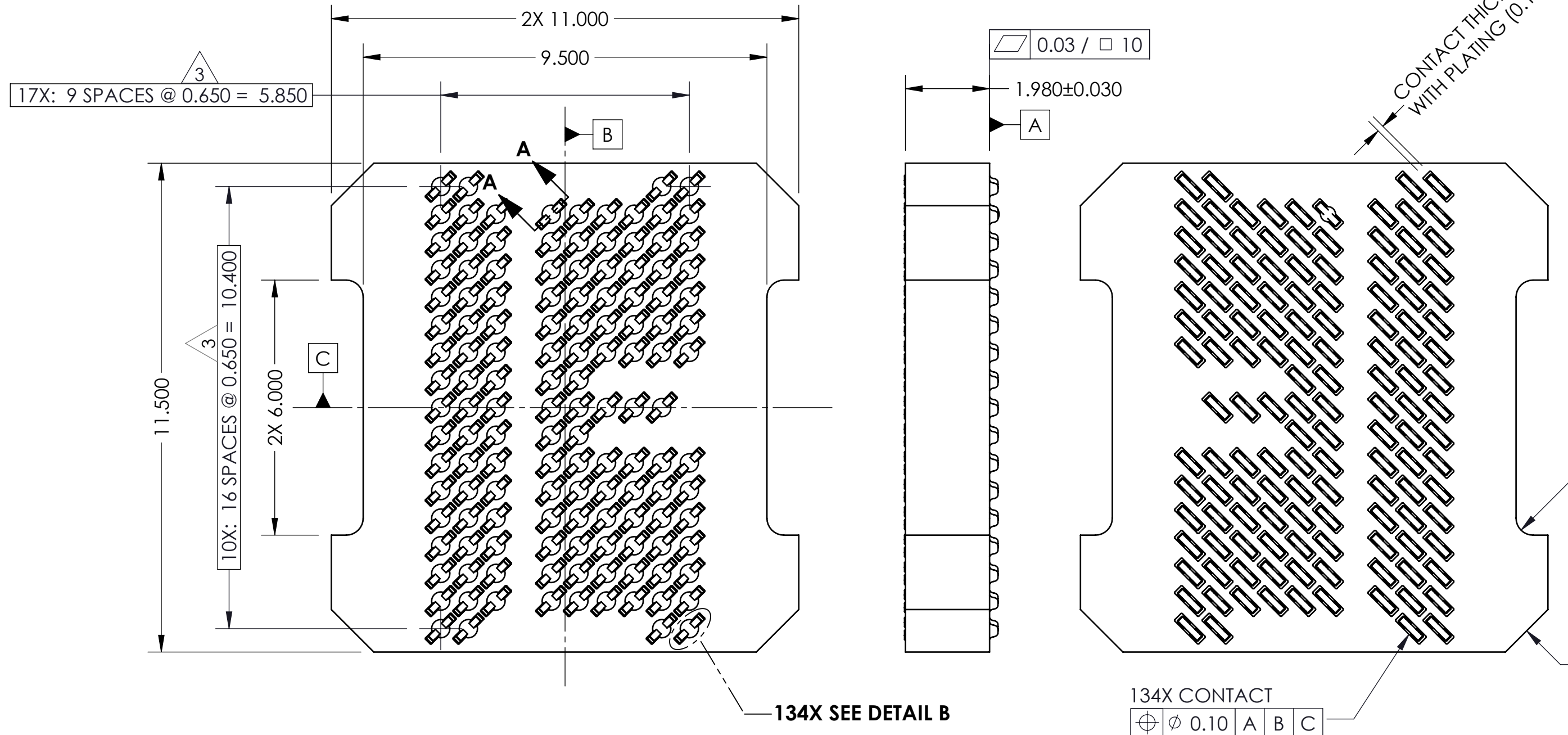

REV	ECO	BY	DESCRIPTION	APV	DATE
A	30630	SK	INITIAL DESIGN	MP	11/19/10
B	31258	AS	UPDATED TITLE BLOCK	MP	02/20/13
C	6882	DJP	UPDATED HSG FROM 4 LAYER TO 5 LAYER.	RS	4/12/22

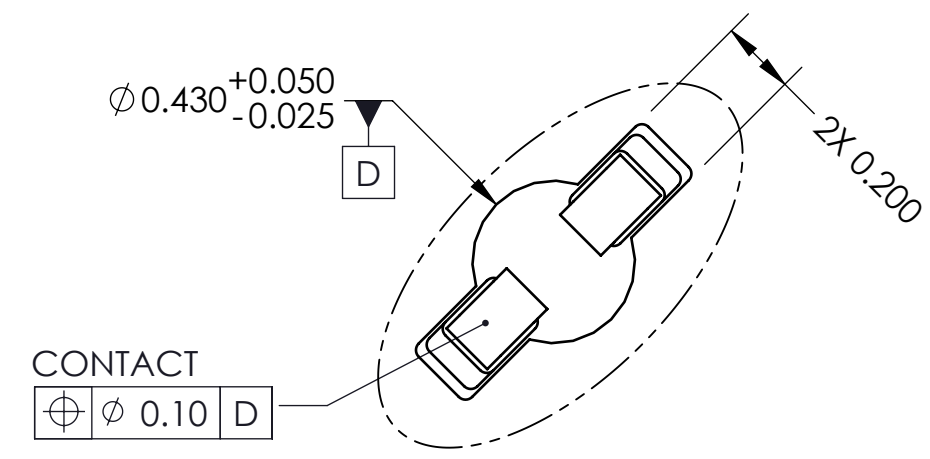

- Notes:
- Footprint part number is 104311-0258.
 - Unless otherwise noted, all features located $\oplus 0.10$ A B C
 - $\triangle 3$ Locates center of contact slots.
 - Datums B and C determined by $\phi 0.430$ opening in corner slots.

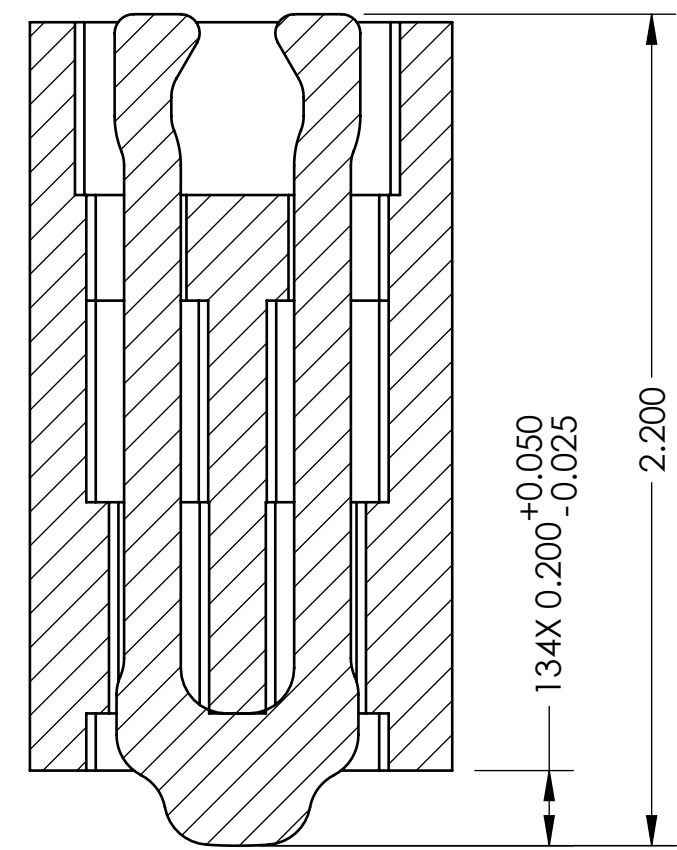

PARTS LIST	
Part Number	Description
104946-0010	SCKT, 134GRY11X11.5-0.65
103864-0061	PRESS, DEV INS, 11X11.5 (SOLD SEP.)
104553-0196	STEN,FLEX, 134GRY11X11.5-0.65 (SOLD SEP.)

 <p>PROPRIETARY AND CONFIDENTIAL</p> <p>THE INFORMATION CONTAINED IN THIS DRAWING IS THE SOLE PROPERTY OF IRONWOOD ELECTRONICS, INC. ANY REPRODUCTION IN PART OR AS A WHOLE WITHOUT THE WRITTEN PERMISSION OF IRONWOOD ELECTRONICS, INC IS PROHIBITED.</p>	UNLESS OTHERWISE SPECIFIED:	NAME	DATE	IRONWOOD ELECTRONICS, INC. 1335 EAGANDALE COURT EAGAN, MINNESOTA 55121 952-229-8200	
	DIMENSIONS ARE IN MILLIMETERS	DRAWN	SK		11/28/2019
	TOLERANCES: ANGULAR: $\pm 1^\circ$ XX ± 0.25 X.XX ± 0.10 X.XXX ± 0.050	CHECKED	MP		11/19/10
	INTERPRET GEOMETRIC TOLERANCING PER:	LEGEND:			TITLE:
MATERIAL	SEE BOM		REVISION CHANGE	SCKT, 134GRY11X11.5-0.65	
FINISH	DO NOT SCALE DRAWING		ITEM NUMBER	DWG. NO.	
				104946-0010	
				REV	
				C	
				SCALE: 10:1 SIZE: C SHEET 1 OF 2	

SOCKET FOR DEVICES THAT ARE WITHIN THESE SPECIFICATIONS					
Lead Count	N	134	Package Size	D	11.00
Columns	ND	10		E	11.50
Rows	NE	17	Ball Spacing	D1	5.85
Pitch	e	0.65		E1	10.40
Ball Size	b	0.35±0.05	Encapsulant/ Top Size	D2	n/a
Total Thickness	A	n/a		E2	n/a
Ball Height	A1	0.25 Min	Pattern Style	IRREGULAR*	
Substrate Thickness	A2	n/a	Perimeter Rows	n/a	
Top Thickness	A3	n/a	Center Array	n/a	
Form Tolerances					
Edge	aaa	0.20	Bottom	ddd	0.15
Substrate	bbb	0.20	Position	eee	0.20
Top	ccc	0.20	Position	fff	0.08

All dimensions are in millimeters.
*See footprint specification for pattern details.

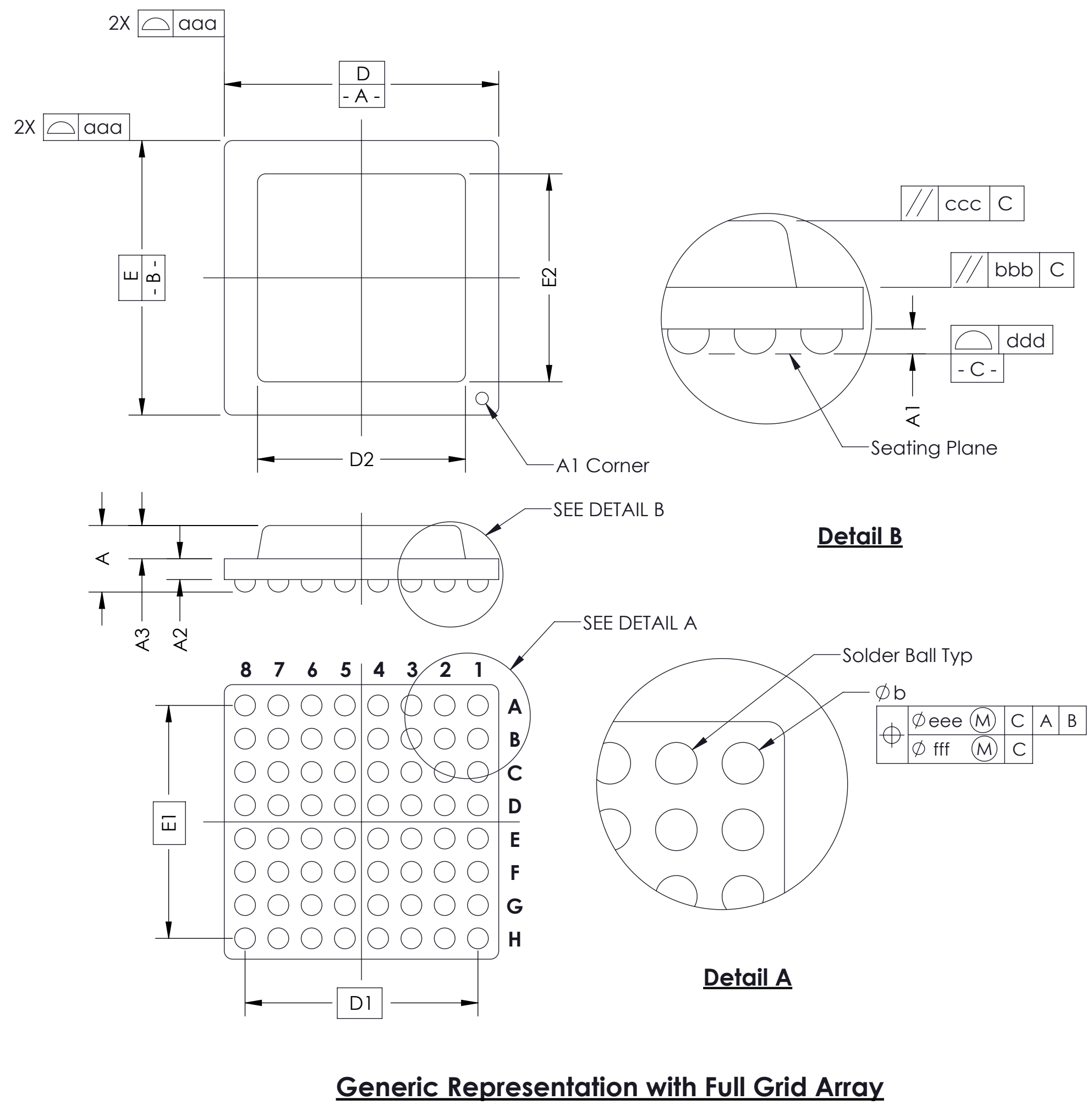
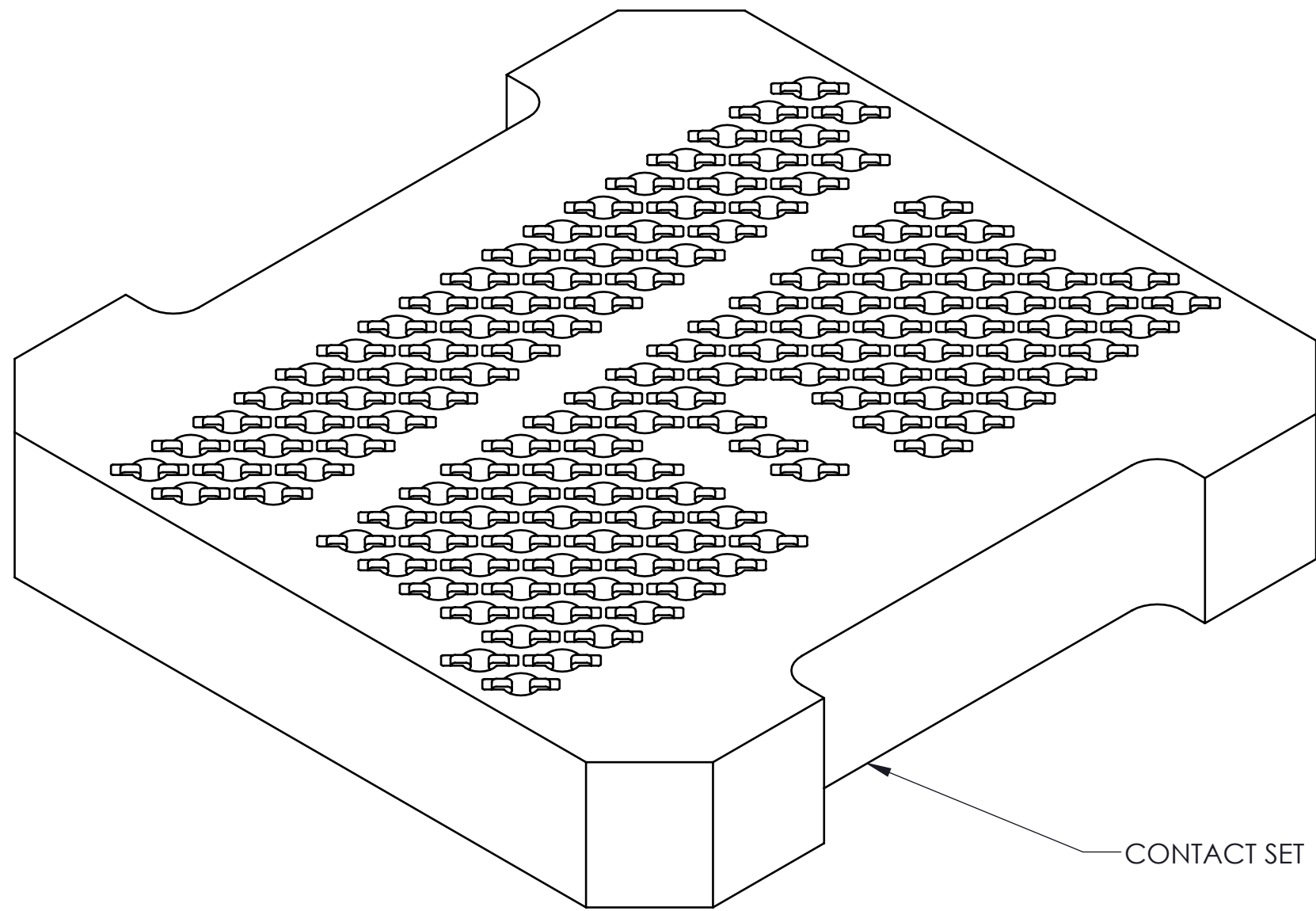

PROPRIETARY AND CONFIDENTIAL

THE INFORMATION CONTAINED IN THIS DRAWING IS THE SOLE PROPERTY OF IRONWOOD ELECTRONICS, INC. ANY REPRODUCTION IN PART OR AS A WHOLE WITHOUT THE WRITTEN PERMISSION OF IRONWOOD ELECTRONICS, INC IS PROHIBITED.

UNLESS OTHERWISE SPECIFIED: DIMENSIONS ARE IN MILLIMETERS TOLERANCES: ANGULAR: ± 1° X.X ±0.25 X.XX ±0.10 X.XXX ±0.050	NAME	DATE	IRONWOOD ELECTRONICS, INC 1335 EAGANDALE CT EAGAN, MINNESOTA 55123 952-229-8200
	SK	11/28/2019	
LEGEND: △ NOTE CALLOUT ◻ REVISION CHANGE ○ ITEM NUMBER	CHECKED	MP	11/19/10

TITLE:
SCKT, 134GRY11X11.5-0.65

DWG. NO. **104946-0010** REV **C**

SCALE: 10:1 SIZE: C SHEET 2 OF 2