

REV	ECO	BY	DESCRIPTION	APV	DATE
A	7923	DJP	INITIAL DESIGN	RS	7/20/23

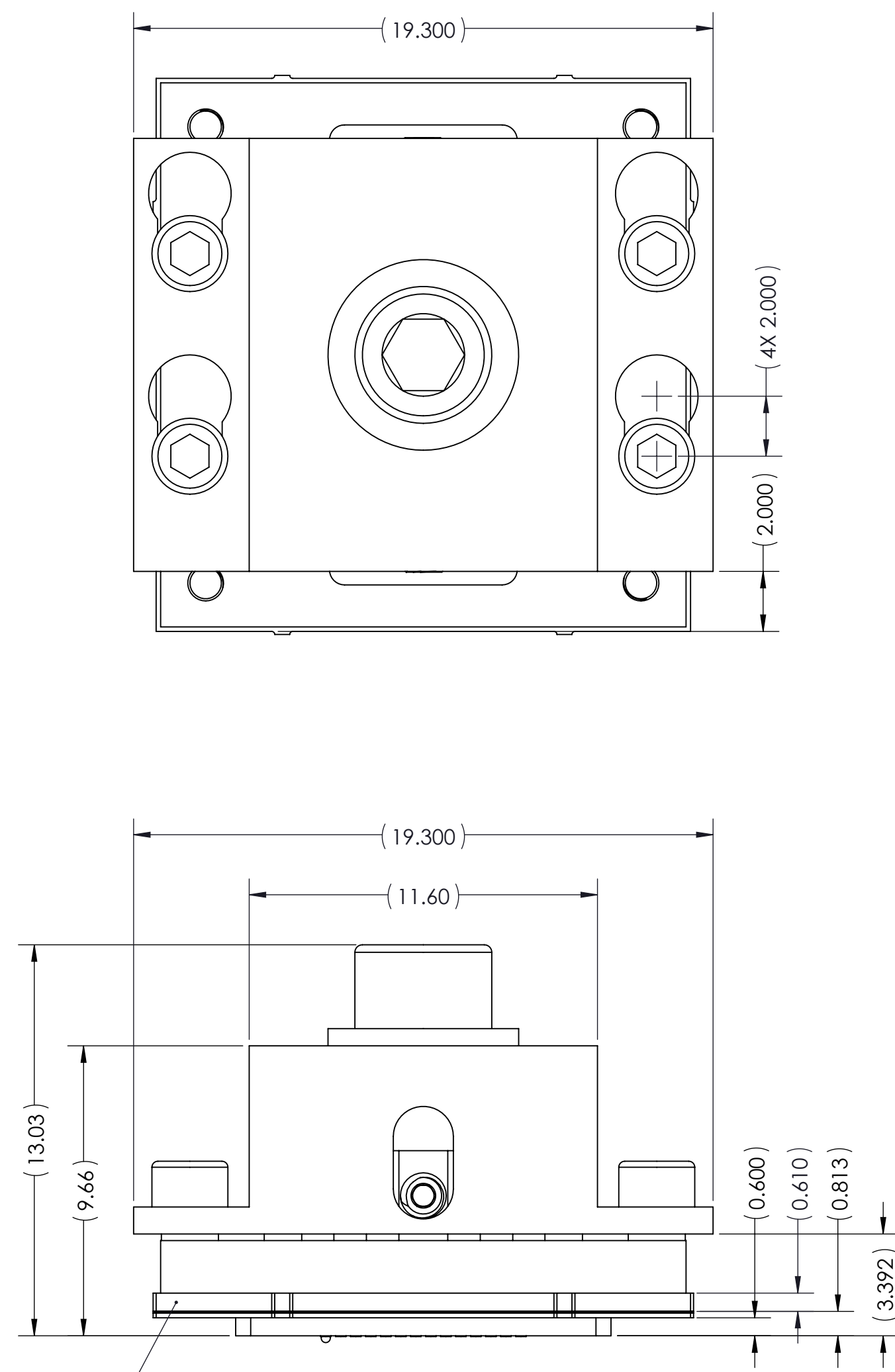

CIRLEX FRAME  
(DEVICE ALIGNMENT)

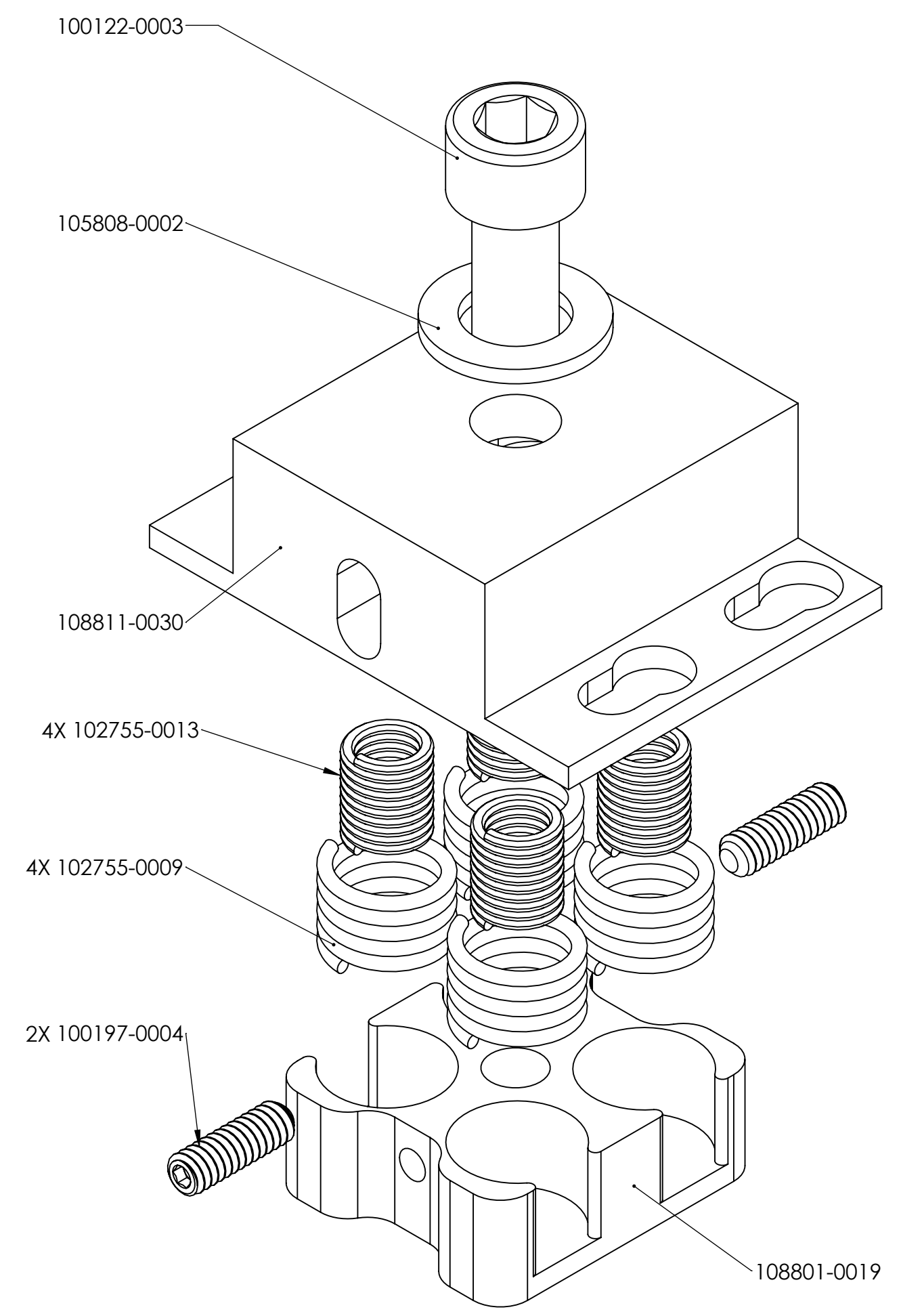

**SLIDING LID ASSEMBLY**  
108810-0050

PART NUMBER	DESCRIPTION
GR1279-0001	SCKT, 153GTNZ 11.5X13.0-0.50, EUT (EUTECTIC SOLDER BALL)
GR1279-0002	SCKT, 153GTNZ 11.5X13.0-0.50, SAC305 (SAC305 SOLDER BALL)
GR1279-0003	SCKT, 153GTNZ 11.5X13.0-0.50, W/O (WITHOUT SOLDER BALL)
108810-0050	ASSY, LID, 11.5X13.0, 4.25, KL (SOLD SEPARATELY)
104553-0330	STEN, FLEX, 153BGA 11.5X13.0-0.50 (SOLD SEPARATELY)

**PROPRIETARY AND CONFIDENTIAL**

THE INFORMATION CONTAINED IN THIS DRAWING IS THE SOLE PROPERTY OF IRONWOOD ELECTRONICS, INC. ANY REPRODUCTION IN PART OR AS A WHOLE WITHOUT THE WRITTEN PERMISSION OF IRONWOOD ELECTRONICS, INC IS PROHIBITED.

UNLESS OTHERWISE SPECIFIED:  
DIMENSIONS ARE IN MILLIMETERS  
TOLERANCES:  
ANGULAR: ± 1°  
X.X ±0.25  
X.XX ±0.10  
X.XXX ±0.050

INTERPRET GEOMETRIC TOLERANCING PER:  
MATERIAL  
SEE B.O.M  
FINISH

DO NOT SCALE DRAWING

DRAWN	DJP	7/20/23
CHECKED	RS	7/20/23

LEGEND:  
 △ NOTE CALLOUT  
 ◻ REVISION CHANGE  
 ○ ITEM NUMBER

**IRONWOOD ELECTRONICS, INC.**  
1335 EAGANDALE COURT  
EAGAN, MINNESOTA 55121  
952-229-8200

TITLE:  
**SCKT, 153GTNZ  
11.5X13.0-0.50, KL**

DWG. NO. **GR1279-XXXX** REV **A**

SCALE: 6:1 SIZE: C SHEET 1 OF 3

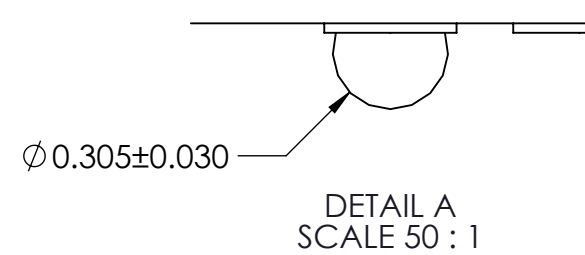
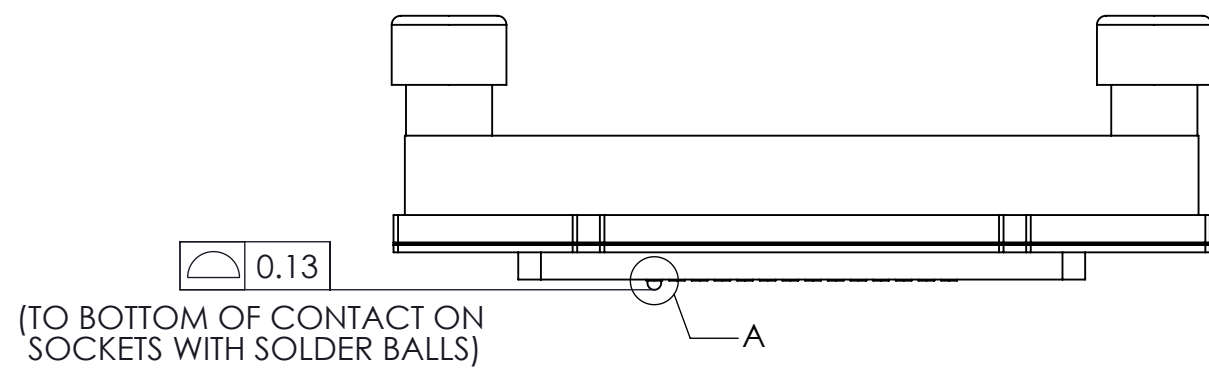
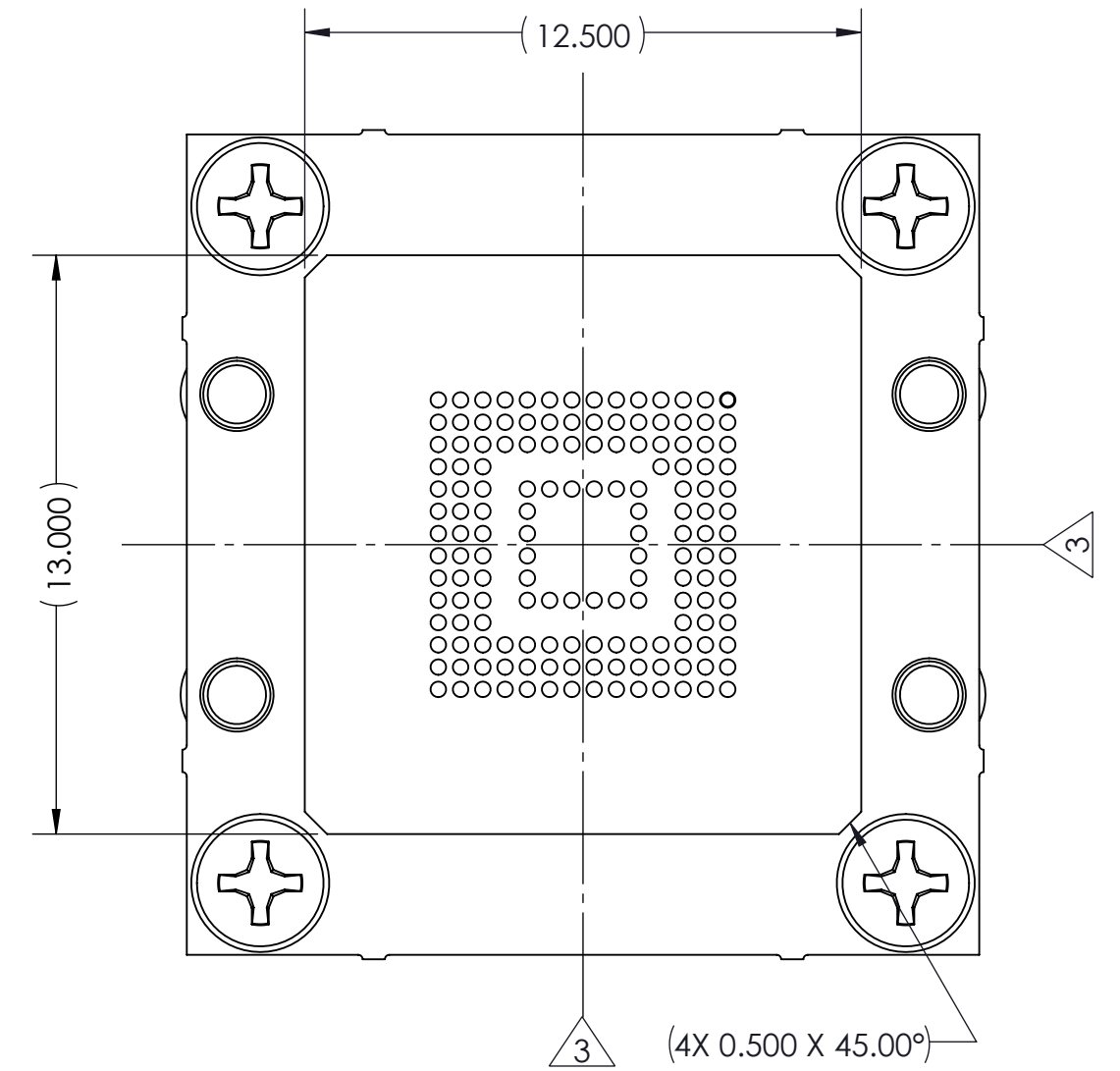
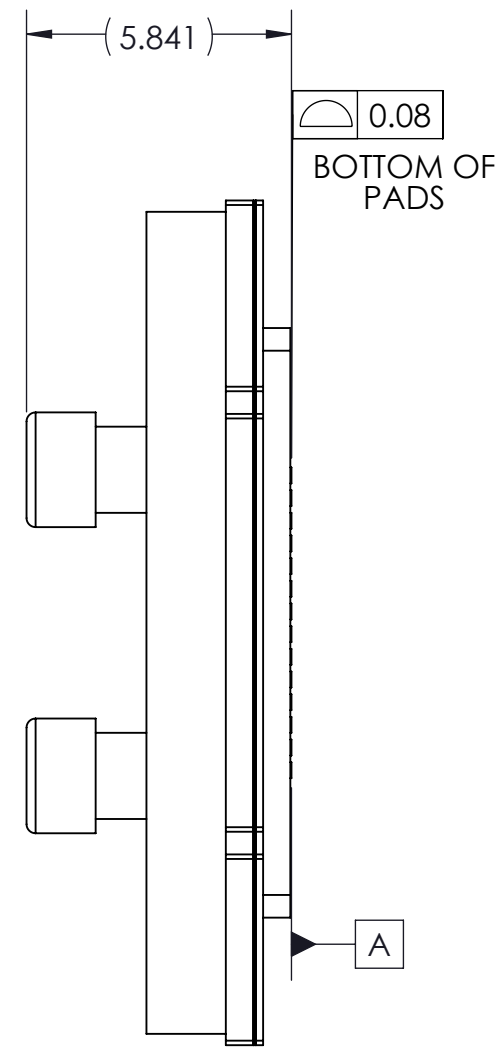
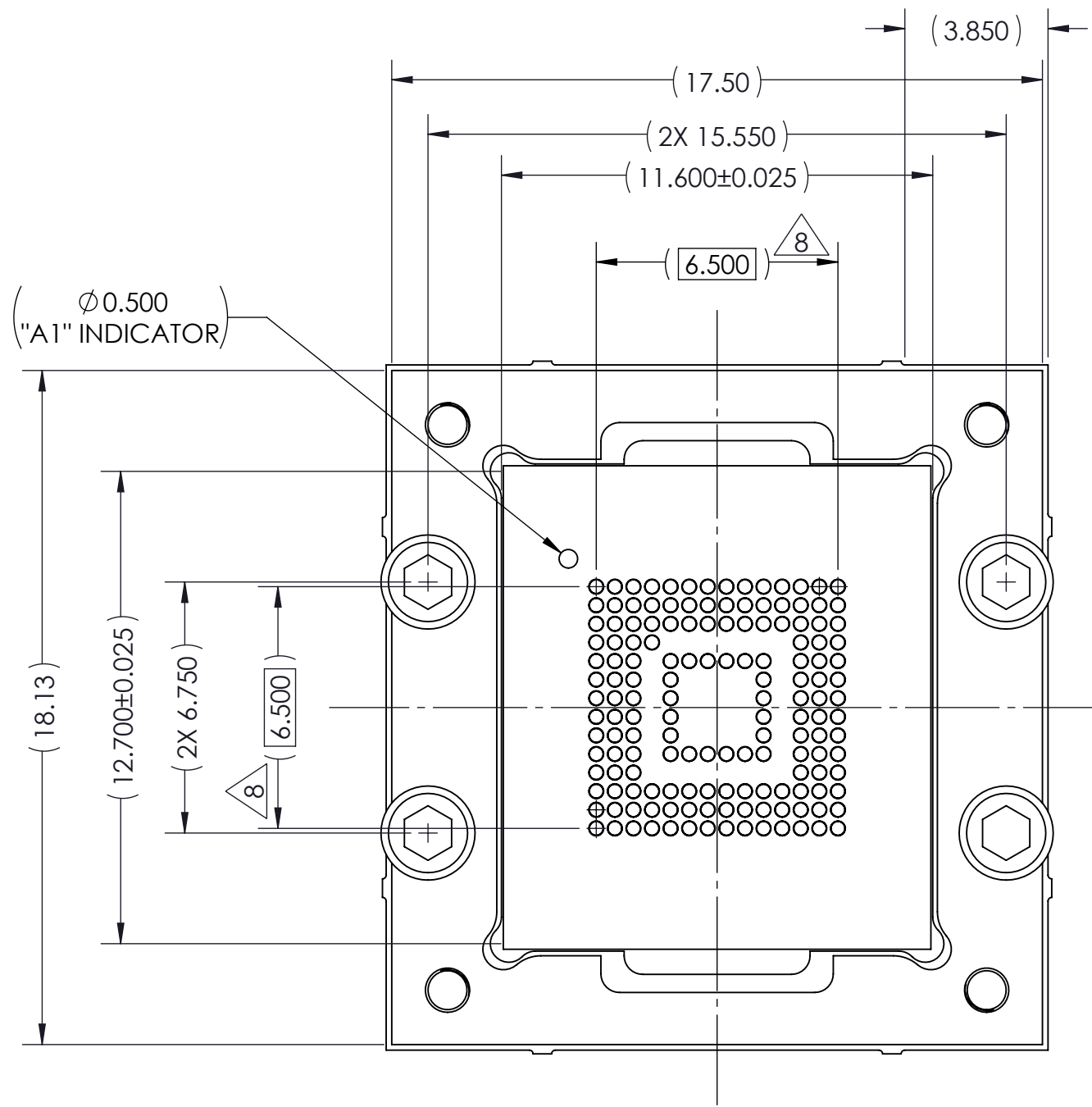

NOTES:

- 1 UNLESS OTHERWISE NOTED, ALL FEATURES LOCATED  $\oplus 0.10$  A B C
- 2 DATUM'S B AND C ARE DETERMINED BY  $\phi 0.400$  FEATURES ON CORNER SLOTS.
- 3 CENTER OF CONTACT PATTERN.
- 5 REFERENCE IRONWOOD ELECTRONICS SPECIFICATION 700001-0001 FOR SOLDER ATTACHMENT.
- 6 REFERENCE IRONWOOD ELECTRONICS SPECIFICATION 700001-0002 FOR APPLICATION NOTES.
- 7 ALL CONTACTS/SOLDER BALLS ARE NOT SHOWN TO MINIMIZE FILE SIZE.
- 8 DIMENSION LOCATES CENTER OF CONTACT/SLOT.
9. FOOTPRINT PART NUMBER IS 104311-0480.

 <b>PROPRIETARY AND CONFIDENTIAL</b> <small>THE INFORMATION CONTAINED IN THIS DRAWING IS THE SOLE PROPERTY OF IRONWOOD ELECTRONICS, INC. ANY REPRODUCTION IN PART OR AS A WHOLE WITHOUT THE WRITTEN PERMISSION OF IRONWOOD ELECTRONICS, INC IS PROHIBITED.</small>	UNLESS OTHERWISE SPECIFIED:		NAME	DATE	<b>IRONWOOD ELECTRONICS, INC.</b> <b>1335 EAGANDALE COURT</b> <b>EAGAN, MINNESOTA 55121</b> <b>952-229-8200</b>	
	DIMENSIONS ARE IN MILLIMETERS		DRAWN	DJP		7/20/23
	TOLERANCES:		CHECKED	RS	7/20/23	<b>TITLE:</b> <b>SCKT, 153GTNZ</b> <b>11.5X13.0-0.50, KL</b>
	ANGULAR: $\pm 1^\circ$		LEGEND:		DWG. NO. <b>GR1279-XXXX</b>   REV <b>A</b>	
X.X $\pm 0.25$		$\triangle$ NOTE CALLOUT	SCALE: 6:1   SIZE: C   SHEET 2 OF 3			
X.XX $\pm 0.10$		$\square$ REVISION CHANGE				
X.XXX $\pm 0.050$		$\circ$ ITEM NUMBER				
INTERPRET GEOMETRIC TOLERANCING PER:		DO NOT SCALE DRAWING				
MATERIAL						
FINISH						

SOCKET FOR DEVICES THAT ARE WITHIN THESE SPECIFICATIONS					
Ball Count	<b>N</b>	153	Package Size	<b>D</b>	11.50
Columns	<b>ND</b>	14		<b>E</b>	13.00
Rows	<b>NE</b>	14	Ball Spacing	<b>D1</b>	6.500
Pitch	<b>e</b>	0.50		<b>E1</b>	6.500
Ball Size	<b>b</b>	0.30 ± 0.05	Encapsulant/ Top Size	<b>D2</b>	N/A
Total Thickness	<b>A</b>	1.00 MAX		<b>E2</b>	N/A
Ball Height	<b>A1</b>	0.15 MIN	Pattern Style	IRREGULAR	
Substrate Thickness	<b>A2</b>	0.92 MAX	Perimeter Rows	N/A	
Top Thickness	<b>A3</b>		Center Array	N/A	

\* ALL DIMENSIONS ARE IN MILLIMETERS.

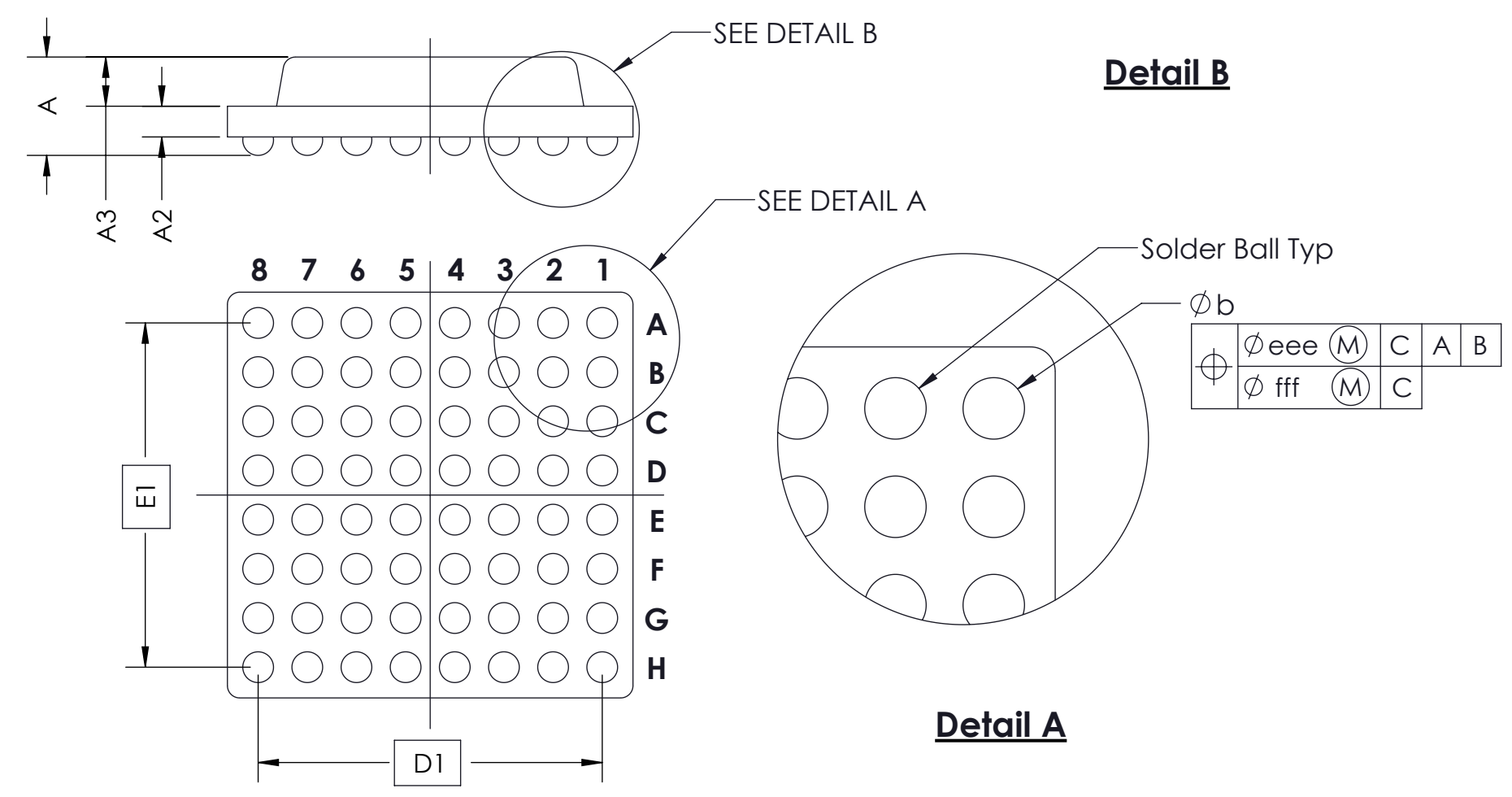
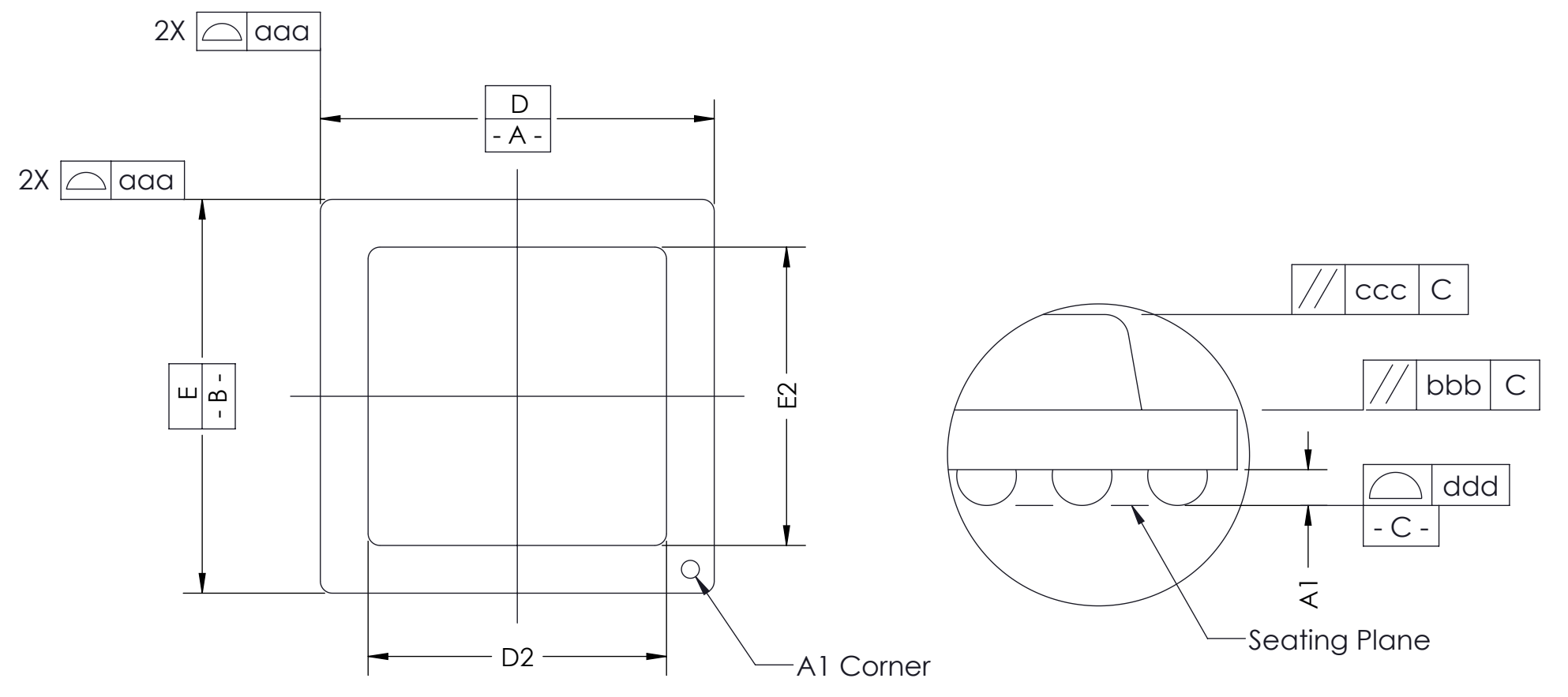

**Generic Representation with Full Grid Array**

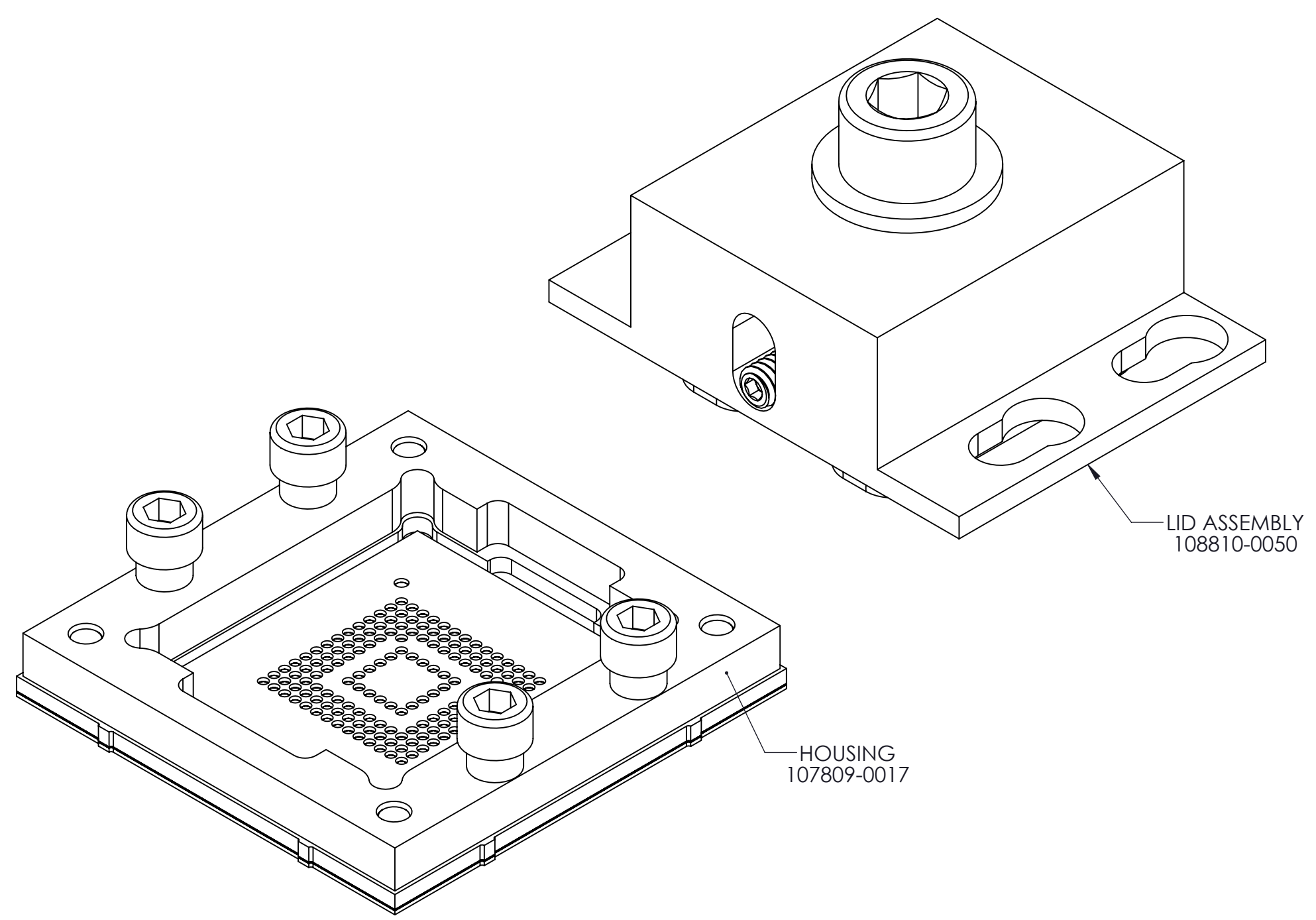

<p><b>PROPRIETARY AND CONFIDENTIAL</b></p> <p>THE INFORMATION CONTAINED IN THIS DRAWING IS THE SOLE PROPERTY OF IRONWOOD ELECTRONICS, INC. ANY REPRODUCTION IN PART OR AS A WHOLE WITHOUT THE WRITTEN PERMISSION OF IRONWOOD ELECTRONICS, INC IS PROHIBITED.</p>	<p>UNLESS OTHERWISE SPECIFIED:</p> <p>DIMENSIONS ARE IN MILLIMETERS</p> <p>TOLERANCES:</p> <p>ANGULAR: ± 1°</p> <p>X.X ± 0.25</p> <p>X.XX ± 0.10</p> <p>X.XXX ± 0.050</p>	<table border="1"> <tr> <td>NAME</td> <td>DATE</td> </tr> <tr> <td>DJP</td> <td>7/20/23</td> </tr> <tr> <td>RS</td> <td>7/20/23</td> </tr> </table>	NAME	DATE	DJP	7/20/23	RS	7/20/23	<p><b>IRONWOOD ELECTRONICS, INC.</b></p> <p>1335 EAGANDALE COURT</p> <p>EAGAN, MINNESOTA 55121</p> <p>952-229-8200</p>
	NAME	DATE							
	DJP	7/20/23							
	RS	7/20/23							
<p>INTERPRET GEOMETRIC TOLERANCING PER:</p> <p>MATERIAL</p> <p>SEE B.O.M</p> <p>FINISH</p> <p>DO NOT SCALE DRAWING</p>	<p>LEGEND:</p> <p>△ NOTE CALLOUT</p> <p>⬡ REVISION CHANGE</p> <p>○ ITEM NUMBER</p>	<p>TITLE:</p> <p><b>SCKT, 153GTNZ</b></p> <p><b>11.5X13.0-0.50, KL</b></p>	<p>DWG. NO.</p> <p><b>GR1279-XXXX</b></p>						
			<p>REV</p> <p><b>A</b></p>						
			<p>SCALE: 6:1</p> <p>SIZE: C</p> <p>SHEET 3 OF 3</p>						