

REV	ECO	BY	DESCRIPTION	APV	DATE
A	30246	KP	Initial Design	ET	04/14/10
B	31308	MP	1) Was 2.250	MP	06/12/13

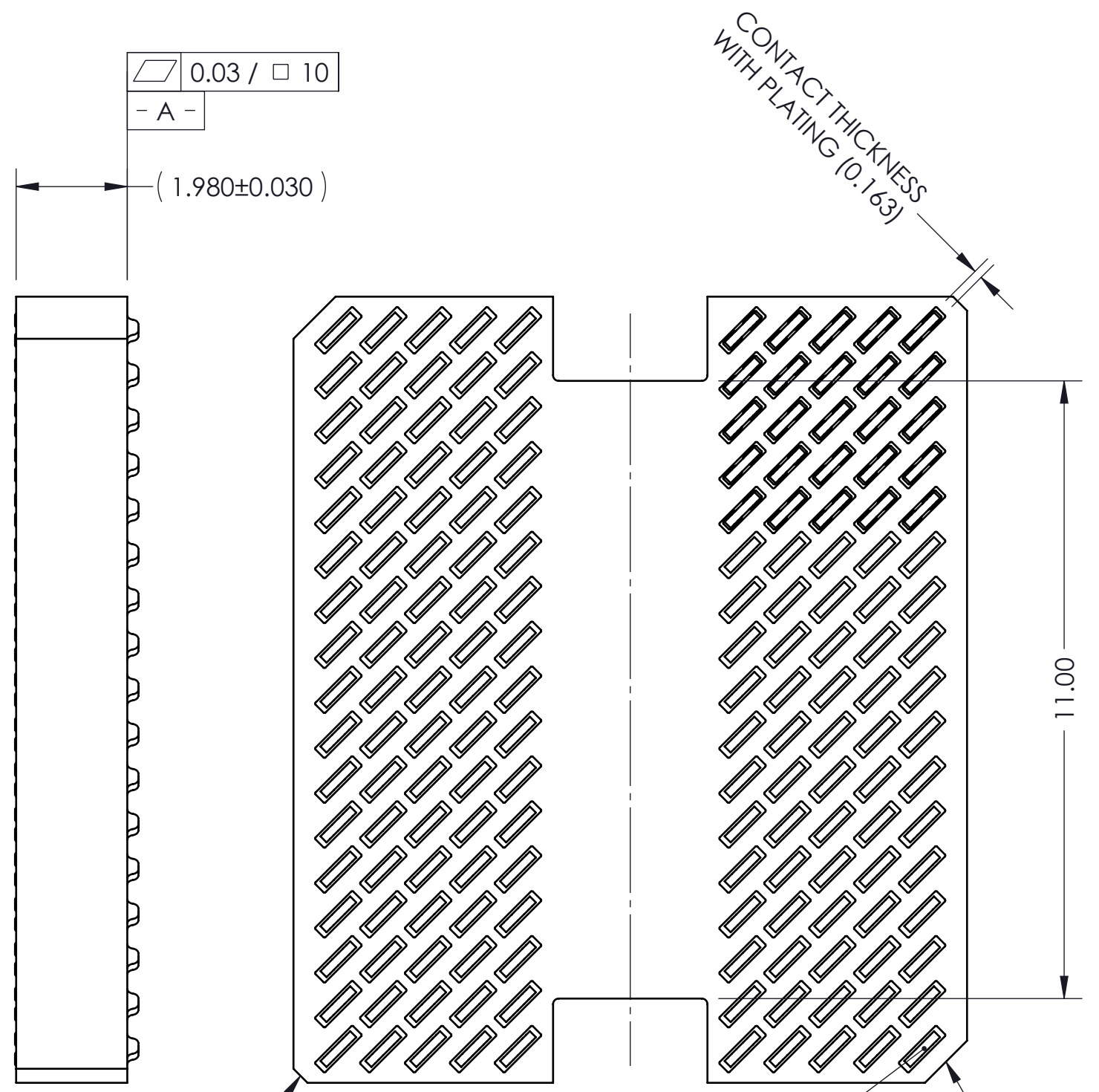

- Notes:
- Footprint part number is 104311-0215
  - Locates center of contact slots.
  - Press size: 12.0 x 14.0
  - Datum B and C determined by  $\phi 0.580$  opening in corner slots.

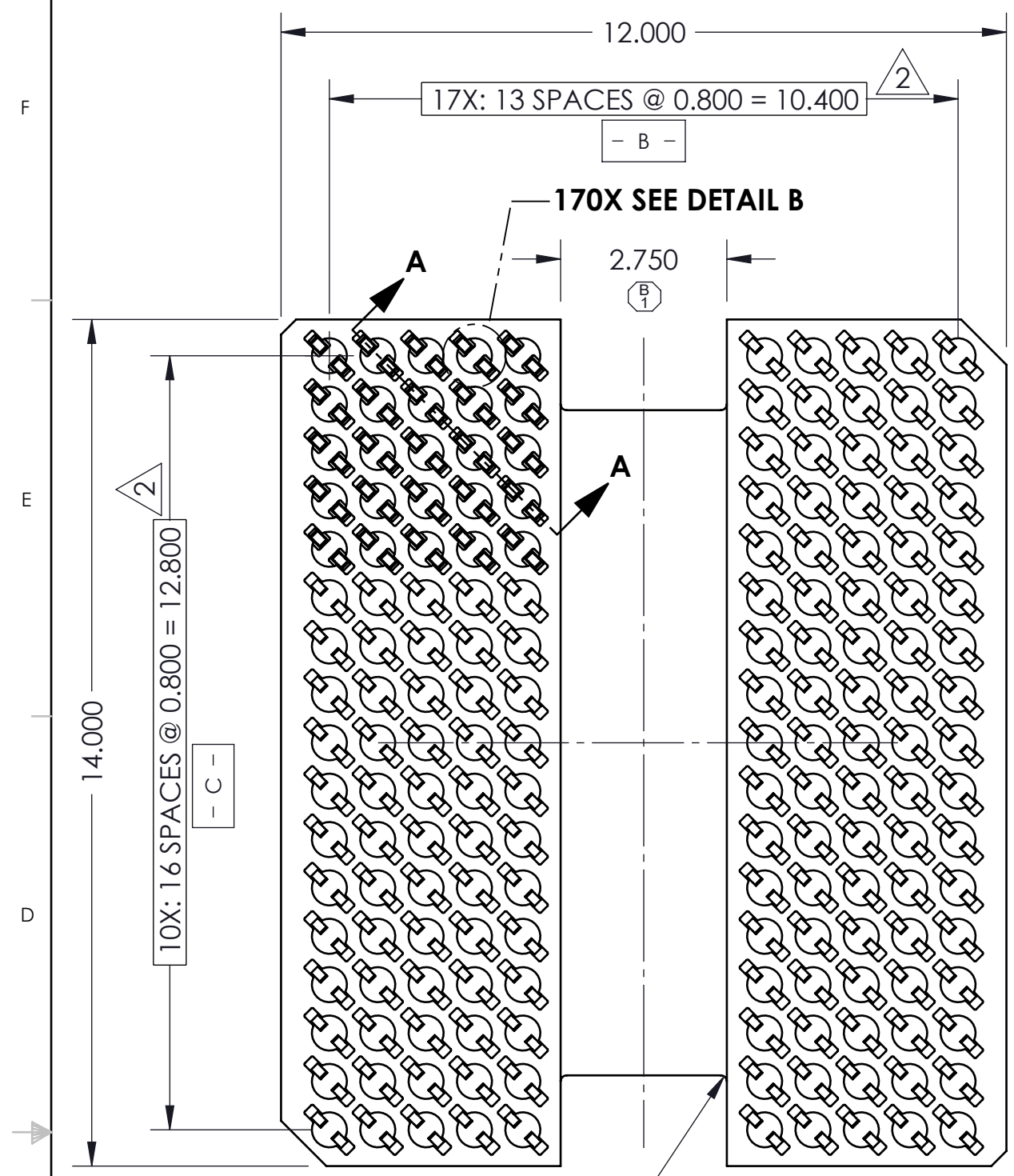
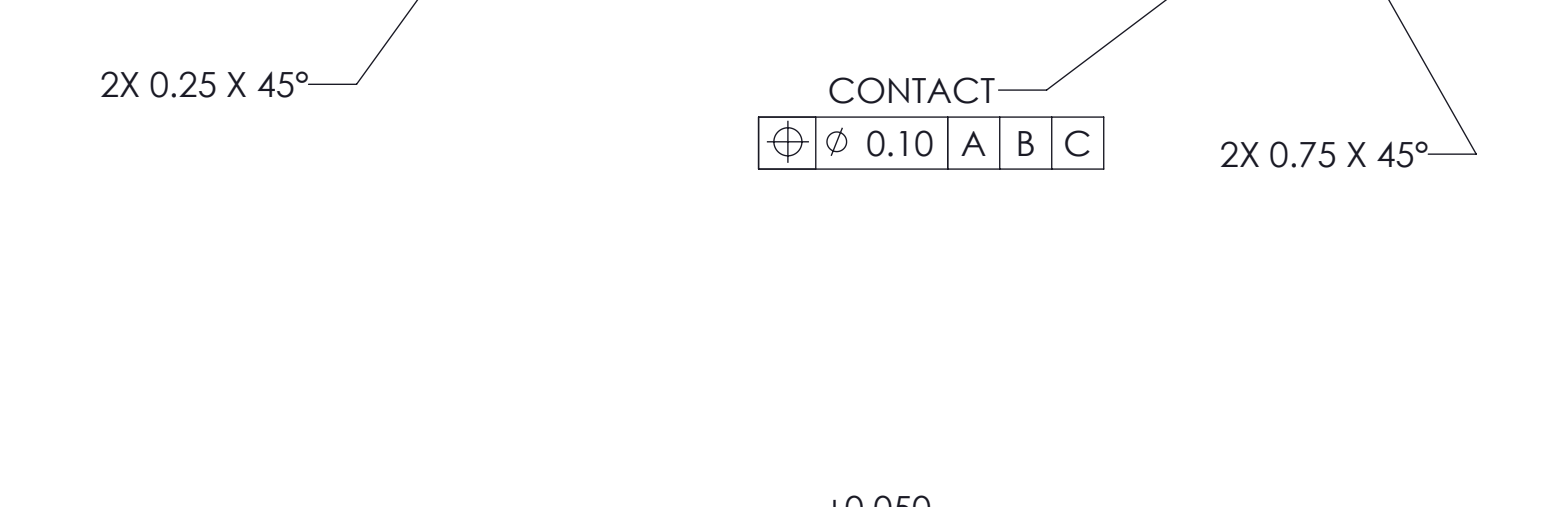
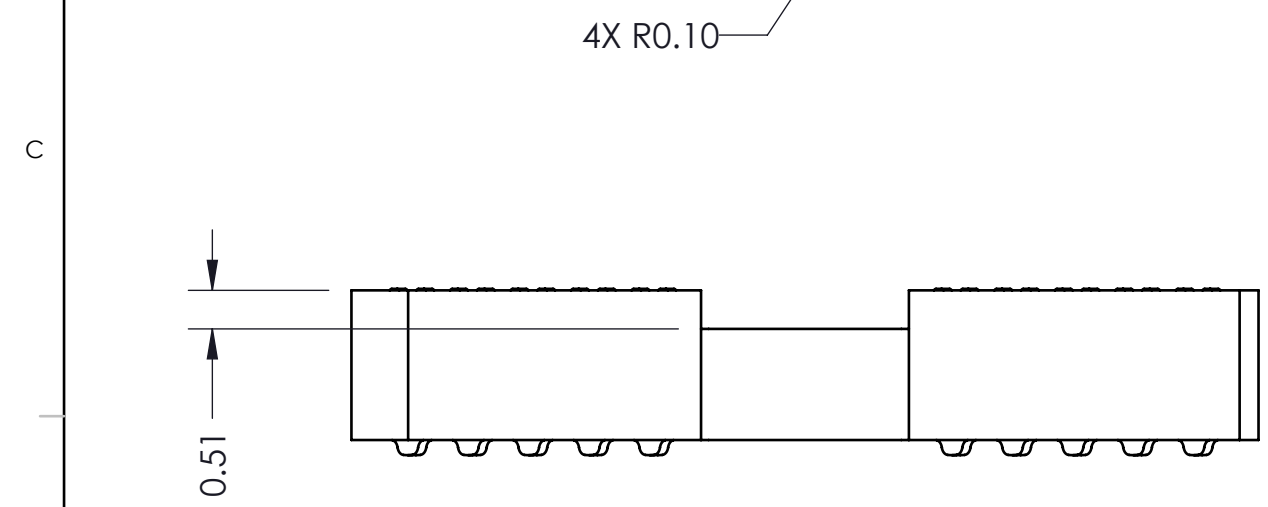

PARTS LIST	
Part Number	Description
105526-0070	SCKT,170GRY12X14-0.80
105528-0070	CS, 170GRY12X14-0.80
103864-0111	PRESS, DEV INS, 12.0X14.0 (SOLD SEP.)
107030-0027	STEN,FLEX, 170GRY12X14-0.80 (SOLD SEP.)

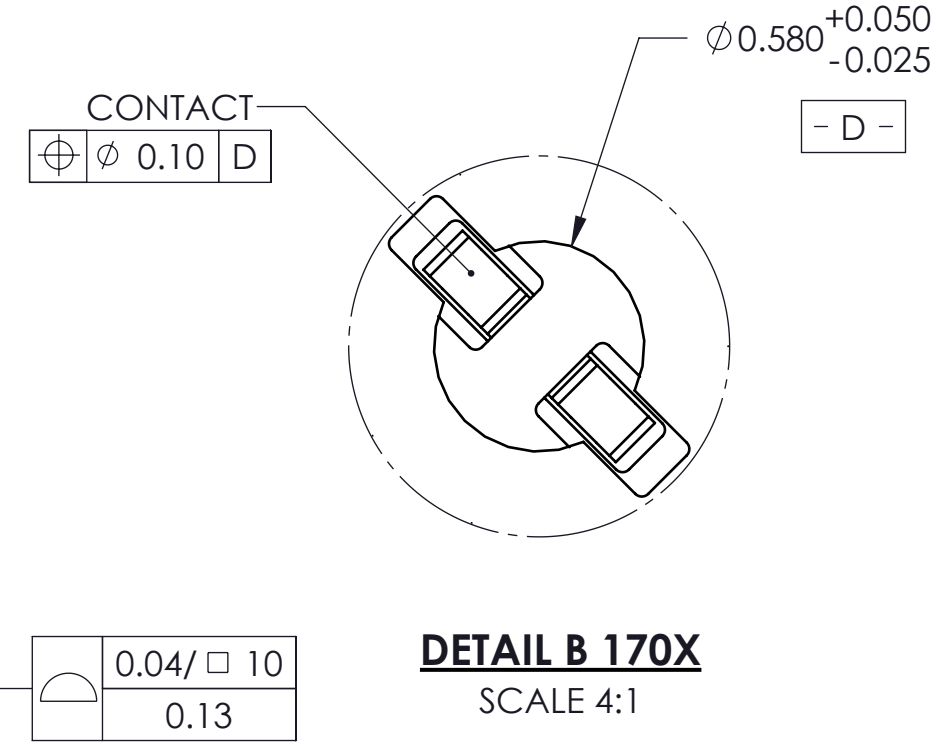
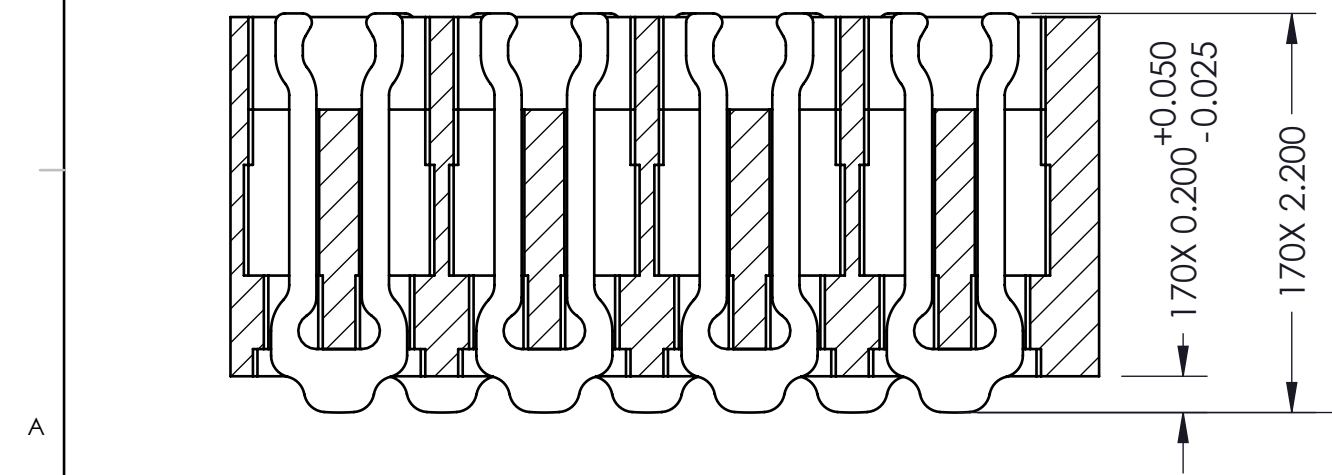

**SECTION A-A**  
Scale 2:1

**DETAIL B 170X**  
SCALE 4:1

<p><b>PROPRIETARY AND CONFIDENTIAL</b></p> <p>THE INFORMATION CONTAINED IN THIS DRAWING IS THE SOLE PROPERTY OF IRONWOOD ELECTRONICS, INC. ANY REPRODUCTION IN PART OR AS A WHOLE WITHOUT THE WRITTEN PERMISSION OF IRONWOOD ELECTRONICS, INC IS PROHIBITED.</p>	UNLESS OTHERWISE SPECIFIED: DIMENSIONS ARE IN MILLIMETERS TOLERANCES: ANGULAR: $\pm 1^\circ$ X.X $\pm 0.25$ X.XX $\pm 0.10$ X.XXX $\pm 0.050$	DRAWN K. Pitney 11/28/2019	NAME K. Pitney	DATE 11/28/2019	<p><b>IRONWOOD ELECTRONICS, INC.</b> 1335 EAGANDALE COURT EAGAN, MINNESOTA 55121 952-229-8200</p>	
	INTERPRET GEOMETRIC TOLERANCING PER:	CHECKED ET	DATE 04/14/10	TITLE: SCKT, 170GRY12X14-0.80, DS		
	MATERIAL SEE BOM	LEGEND: △ NOTE CALLOUT □ REVISION CHANGE ○ ITEM NUMBER		DWG. NO. <b>105526-0070</b>		REV <b>B</b>
	FINISH	DO NOT SCALE DRAWING		SCALE: 10:1		SIZE: C

SOCKET FOR DEVICES THAT ARE WITHIN THESE SPECIFICATIONS					
Lead Count	<b>N</b>	170	Package Size	<b>D</b>	12.0
Columns	<b>ND</b>	14	Ball Spacing	<b>E</b>	14.0
Rows	<b>NE</b>	17	Encapsulant/ Top Size	<b>D1</b>	10.40
Pitch	<b>e</b>	0.80	Encapsulant/ Top Size	<b>E1</b>	12.80
Ball Size	<b>b</b>	0.45±0.05	Pattern Style	<b>D2</b>	n/a
Total Thickness	<b>A</b>	N/A	Pattern Style	<b>E2</b>	n/a
Ball Height	<b>A1</b>	0.275 Min	Perimeter Rows	Irregular*	
Substrate Thickness	<b>A2</b>	N/A	Center Array	n/a	
Top Thickness	<b>A3</b>	N/A			
Form Tolerances					
Edge	<b>aaa</b>	0.20	Bottom	<b>ddd</b>	0.15
Substrate	<b>bbb</b>	0.20	Position	<b>eee</b>	0.20
top	<b>ccc</b>	0.20	Position	<b>fff</b>	0.08

All dimensions are in millimeters.  
\*See footprint specification for pattern details.

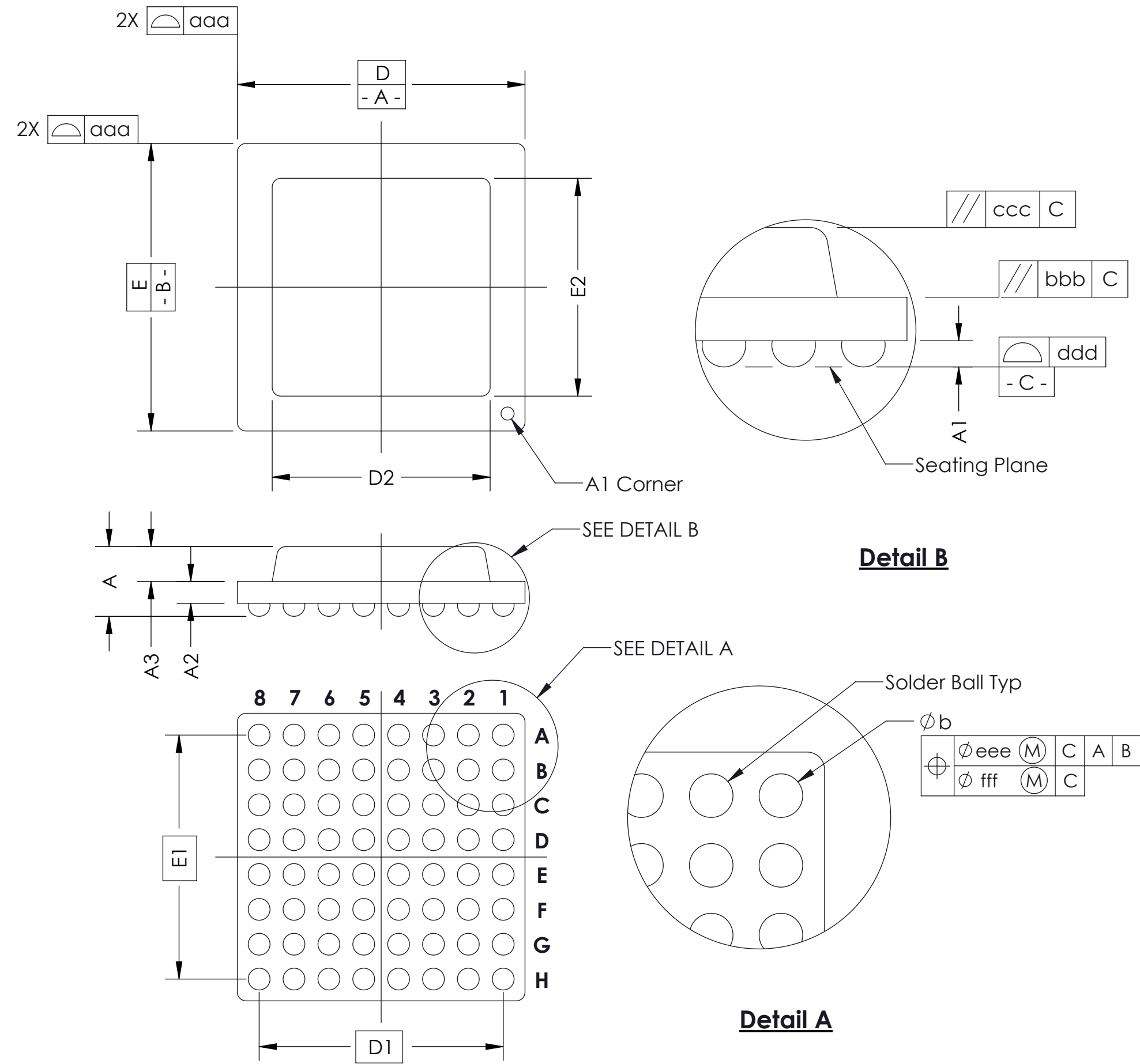
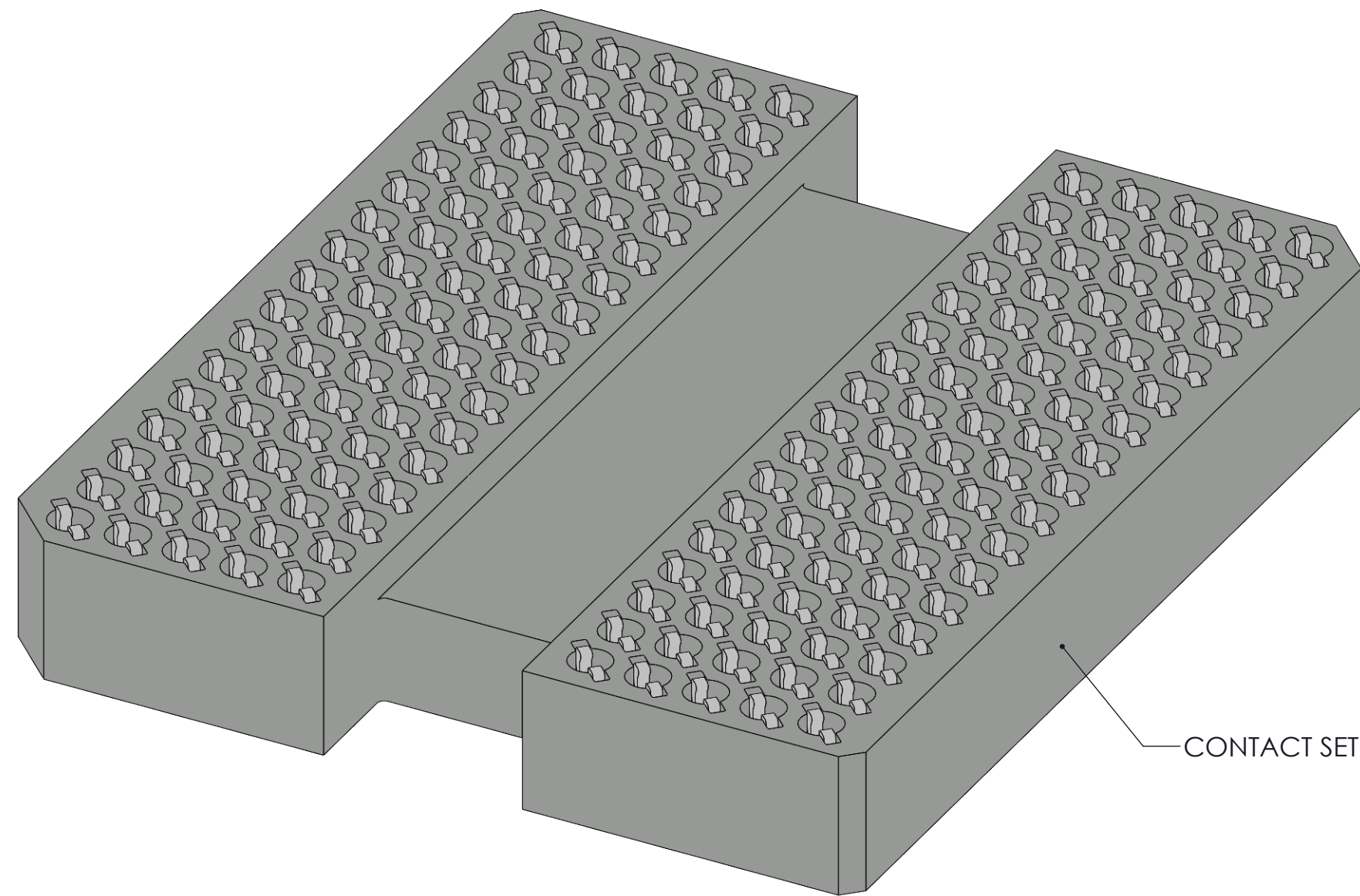

**Generic Representation with Full Grid Array**

PROPRIETARY AND CONFIDENTIAL						
THE INFORMATION CONTAINED IN THIS DRAWING IS THE SOLE PROPERTY OF IRONWOOD ELECTRONICS, INC. ANY REPRODUCTION IN PART OR AS A WHOLE WITHOUT THE WRITTEN PERMISSION OF IRONWOOD ELECTRONICS, INC IS PROHIBITED.						
UNLESS OTHERWISE SPECIFIED:	NAME	DATE	IRONWOOD ELECTRONICS, INC.			
DIMENSIONS ARE IN MILLIMETERS	DRAWN	K. Pitney	1335 EAGANDALE COURT			
TOLERANCES:	CHECKED	ET	EAGAN, MINNESOTA 55121			
ANGULAR: ± 1°		04/14/10	952-229-8200			
X.X ±0.25						
X.XX ±0.10					TITLE:	
X.XXX ±0.050					SCKT, 170GRY12X14-0.80, DS	
LEGEND:	DWG. NO.		REV			
△ NOTE CALLOUT	105526-0070		B			
◻ REVISION CHANGE	SCALE: 10:1	SIZE: C	SHEET 2 OF 2			
○ ITEM NUMBER						