



QFN 35 Standard Sockets

QFN Sockets for JEDEC MO220 QFN Devices Clam Shell Lid – 10k Insertions – S21 Electrical Performance >10 GHz

High Performance Sockets for QFN 2 x 2 – 12 x 12

Ironwood Electronics Standard QFN test sockets are designed for today’s high performance QFN and DFN packages Used for development, characterization, at speed burn-in and low volume production manual testing.

FEATURES AND BENEFITS

Signal performance	Miniature stamped contacts provide extremely short signal path
Oxide-cutting wipe action	The QFN35 contact wipes the package pad, cutting through solder oxides
Near-device decoupling	Small footprints, with large underside frame decoupling pockets designed to standard dimensioned packages, allow for near-device placement of passive components
Reduced ground inductance	Multiple compliant ground contacts reduce ground inductance and provide a thermal path through the PCB. A solid ground block can be incorporated for further product enhancements
Replaceable contact sets	Sockets with replaceable contact sets offer a significant cost savings vs. the purchase of a new socket

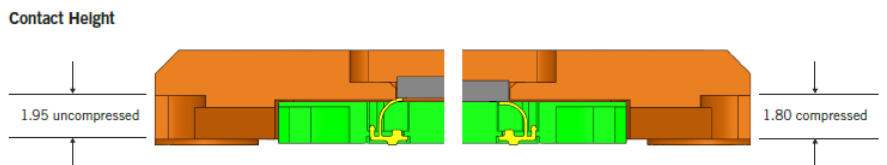
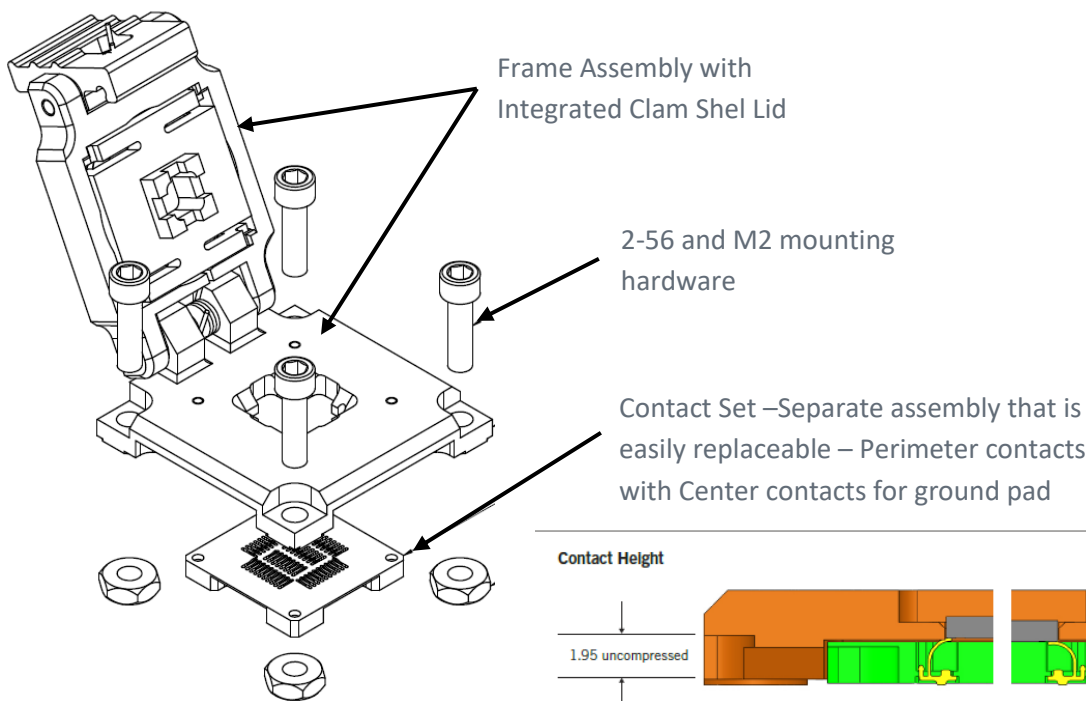

The table below is the JEDEC MO-220 listing of the “Thermally Enhanced Thin and Very Thin” QFN devices
 The Ironwood part number listed designates the socket we have designed for the various standard QFN devices by BODY SIZE LEAD COUNT and PITCH.

The design has a press that will accommodate the device thickness in the range of the MIN and MAX listed. If you have a device thickness outside the limits we can accommodate this easily with either a modified press or one from another design

The contacts in the center for the ground pad lists the Minimum size the socket will accommodate. Other ground configuration can be designed and Solid ground blocks also can be design for maximum thermal dissipation when required.

Ironwood also has 100’s of additional designs for other variations of QFN, DFN and SO devices.

Always submit a package drawing so we can ensure the proper fit

CAD Footprint drawings are available for all the socket part numbers listed for your PCB layout.

Ironwood QFN35 Socket Assembly Part Number	JEDEC MO-220 QFN Devices			Device Press (other Presses available for Device thickness outside the range listed)		Ground Contacts	
	BODY SIZE (D) x (E)	Lead Pitch (e)	Lead Count	MIN "A" (Device Thickness)	MAX "A" (Device Thickness)	MIN Ground Pad size (D1) x (E1)	
	2.00	2.00	0.50	8			
	3.00	3.00	0.80	4			
			0.65	8			
			0.65	12			
106458-0211			0.65	14	0.65	1.00	none
			0.50	12			
106458-0005			0.50	16	0.65	1.00	1.0 x 1.0
			0.40	16			
106458-0197			0.40	20	0.70	1.05	1.0 x 1.0
	3.50	3.50	0.50	20			
106458-0094	3.50	4.50	0.50	24	0.75	1.10	1.5 x 2.5
	3.00	4.00	0.80	8			
			0.65	12			
			0.50	16			
106458-0080			0.50	20	0.75	1.10	1.5 x 2.5
	4.00	4.00	0.80	12			
			0.80	14			
			0.65	12			
106458-0001			0.65	16	0.60	0.95	2.0 x 2.0
			0.50	14			
			0.50	16			
106458-0007			0.50	20	0.65	1.00	1.5 x 1.5
106458-0008			0.50	24	0.65	1.00	1.5 x 1.5
			0.50	28			
			0.40	28			

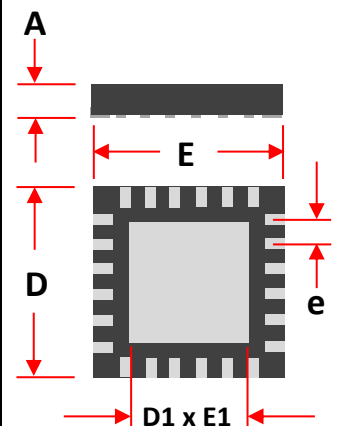

Ironwood QFN35 Socket Assembly Part Number	JEDEC MO-220 QFN Devices			Device Press (other Presses available for Device thickness outside the range listed)		Ground Contacts	
	BODY SIZE (D) x (E)		Lead Pitch	Lead Count	MIN "A" (Device Thickness)	MAX "A" (Device Thickness)	MIN Ground Pad size (D1 x E1)
	4.00	5.00	0.80	10			
			0.80	14			
			0.80	16			
			0.65	18			
			0.50	28			
			0.50	24			
106458-0122			0.40	32	0.65	1.00	2.0 x 3.0
			0.40	34			
	4.50	5.50	0.50	32			
	4.50	6.50	0.50	36			
106458-0134	5.00	5.00	0.80	16	0.75	1.10	3.0 x 3.0
			0.80	20			
106458-0010			0.65	20	0.75	1.10	3.0 x 3.0
106458-0047			0.65	24	0.75	1.10	1.5 x 1.5
106458-0011			0.50	28	0.65	1.00	1.5 x 1.5
106458-0012			0.50	32	0.65	1.00	1.5 x 1.5
			0.40	36			
106458-0037			0.40	40	0.65	1.00	3.0 x 3.0
	5.00	6.00	0.80	18			
			0.80	20			
			0.65	22			
	5.00	7.00	0.50	32			
106458-0163			0.50	38	0.75	1.10	2.5 x 5.0
			0.50	40			
	5.50	6.50	0.50	40			
	6.00	6.00	0.80	20			
			0.80	24			
106458-0113			0.65	28	0.75	1.10	2.0 x 2.0
			0.65	24			
			0.65	32			
106458-0015			0.50	36	0.65	1.00	4.0 x 4.0
			0.50	38			
106458-0016			0.50	40	0.65	1.00	4.0 x 4.0
			0.50	32			
106458-0038			0.40	48	0.65	1.00	4.0 x 4.0
	7.00	7.00	0.80	28			
			0.65	32			
			0.65	36			
			0.65	32			
			0.50	40			
106458-0019			0.50	44	0.65	1.00	4.0 x 4.0
106458-0020			0.50	48	0.65	1.00	4.0 x 4.0
106458-0039			0.40	56	0.75	1.10	4.0 x 4.0

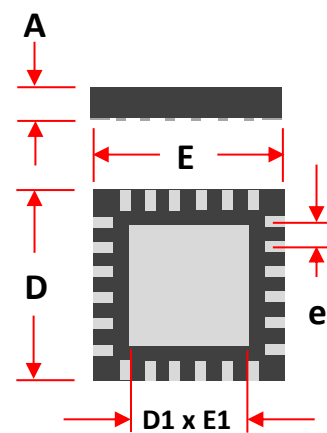

Ironwood QFN35 Socket Assembly Part Number	JEDEC MO-220 QFN Devices			Device Press (other Presses available for Device thickness outside the range listed)		Ground Contacts	
	BODY SIZE (D) x (E)	Lead Pitch (e)	Lead Count	MIN "A" (Device Thickness)	MAX "A" (Device Thickness)	MIN Ground Pad size (D1) x (E1)	
	7.00	9.00	0.50	38			
	8.00	8.00	0.80	28			
			0.80	32			
			0.65	36			
			0.65	40			
			0.65	44			
			0.50	48			
			0.50	52			
106458-0024					0.50	56	0.65
106458-0040			0.40	64	0.65	1.00	5.0 x 5.0
106458-0041			0.40	68	0.70	1.05	5.0 x 5.0
106458-0025	9.00	9.00	0.80	36	0.65	1.00	5.2 x 5.2
			0.65	48			
			0.65	44			
			0.50	56			
106458-0027			0.50	60	0.65	1.00	5.2 x 5.2
106458-0028			0.50	64	0.65	1.00	5.0 x 5.0
			0.40	72			
106458-0043			0.40	76	0.65	1.00	5.0 x 5.0
	10.00	10.00	0.50	64			
106458-0183			0.50	68	0.65	1.00	none
106458-0032			0.50	72	0.65	1.00	6.2 x 6.2
			0.40	84			
106458-0044			0.40	88	0.65	1.00	6.0 x 6.0
	12.00	12.00	0.50	80			
106458-0098			0.50	88	0.65	1.00	6.5 x 6.5
106458-0155			0.40	100	0.70	1.05	6.5 x 6.5
			0.40	108			

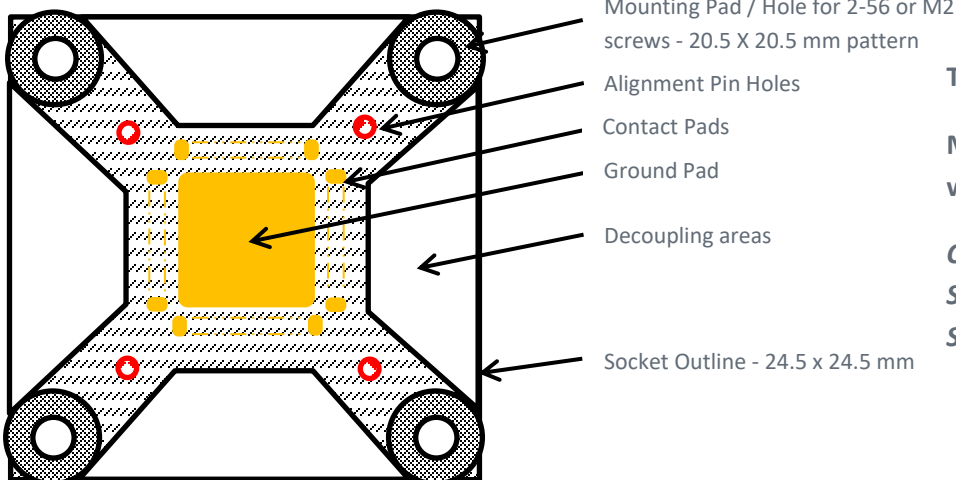
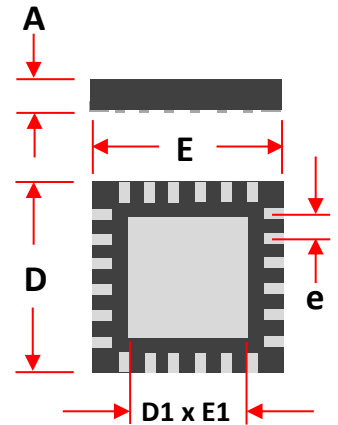

Typical Footprint Layout

Mounting and Alignment Pin Pattern with Close Decoupling areas

Contact HISO Technologies for Specific Footprint Drawings for each Socket Design

MECHANICAL SPECIFICATIONS

Contact life	10k insertions
Normal force	40 grams/contact
Vertical compression	0.15mm
Contact height	1.95 mm

MATERIAL SPECIFICATIONS

Contact base material	Copper (Cu) alloy
Contact plating	Gold (Au) over Nickel (Ni)
Housing	Polyimide (Cirlex®)
Frame	Torlon® 5030, Ultem2300 or equivalent
Environmental	-55° C to 155° C

Overall performance may vary based on applications requirements and maintenance schedules. Additional performance data may be available on request.

ELECTRICAL SPECIFICATIONS

P2A configuration	0.4 mm pitch	0.5 mm pitch*
GSG Loop inductance	1.03 nH	1.23 nH
Self inductance	0.800 nH	0.936 nH
Mutual inductance	0.086 nH	0.085 nH
Capacitance (GSG - Signal pin to Return)	0.234 pF	0.213 pF
Mutual capacitance	0.016 pF	0.014 pF
S21 Insertion loss (GSG)	-1 dB @ 17.4 GHz	-1 dB @ 11.0 GHz
S11 Return loss (GSG)	-20 dB @ 3.5 GHz	-20 dB @ 3.0 GHz
S41 Crosstalk (GSSG)**	-20 dB @ 7.6 GHz	-20 dB @ 4.8 GHz
Impedance	66.3 Ω	76 Ω
Time delay	14.3 ps	15.2 ps
Current Carrying Capacity (GSG)	3 A	3 A
CRES	< 25 mΩ	< 25 mΩ

* Specification based on lab measurements.

** All GSSG Crosstalk values are based on simulation.

PERFORMANCE

